

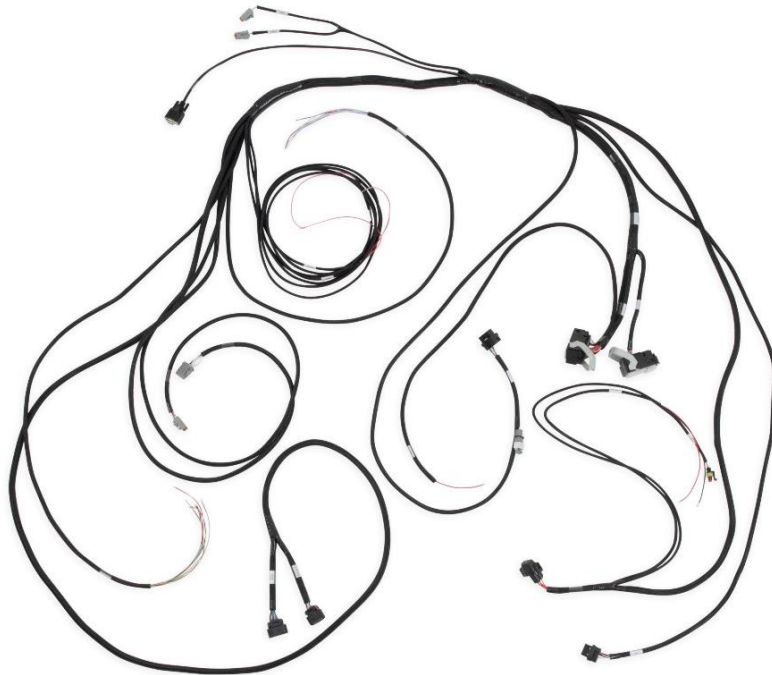

30-8604

**Front Low Voltage VCU275 Harness System
User Manual**



AEM

2205 126th Street Unit A, Hawthorne, CA. 90250

Phone: (310) 484-2322 Fax: (310) 484-0152

https://www.holley.com/brands/aem_ev/

Instruction Part Number: 10-8604_REV_A

Document Build 2024-05-22

Disclaimer**DANGER!****READ THIS BEFORE INSTALLING/USING!**

USE THIS PRODUCT WITH EXTREME CAUTION. MISUSE AND/OR IMPROPER INSTALLATION CAN CAUSE SIGNIFICANT DAMAGE TO YOUR VEHICLE AND PROPERTY BELONGING TO YOU OR OTHERS, AS WELL AS PERSONAL INJURY OR DEATH. IF YOU ARE NOT TRAINED IN ELECTRICAL ENGINEERING OR COMPLETELY FAMILIAR WITH THE SAFETY REQUIREMENTS OF HIGH VOLTAGE ELECTRIC VEHICLES, AND/OR ARE NOT WELL-VERSED IN CONFIGURING THE NECESSARY CONTROL CALIBRATIONS IN THE AEM VEHICLE CONTROL UNIT (VCU), DO NOT UNDER ANY CIRCUMSTANCES ATTEMPT TO INSTALL OR USE THIS PRODUCT. REFER THE INSTALLATION AND CALIBRATION TO A REPUTABLE INSTALLATION FACILITY, OR CONTACT AEM EV FOR A REFERRAL IN YOUR AREA. IT IS THE RESPONSIBILITY OF THE INSTALLER TO ULTIMATELY CONFIRM THAT THE INSTALLATION AND CALIBRATIONS ARE SAFE FOR ITS INTENDED USE.

AEM AND ITS AFFILIATES, SHAREHOLDERS, DIRECTORS, OFFICERS, AGENTS, REPRESENTATIVES, SUCCESSORS AND ASSIGNS (COLLECTIVELY, THE "AEM PARTIES") HOLD NO RESPONSIBILITY FOR ANY DAMAGE OR INJURY THAT RESULTS FROM INSTALLATION OR MISUSE OF ANY AEM PRODUCTS. EXCEPT FOR, TO THE EXTENT APPLICABLE TO THE PRODUCTS YOU HAVE PURCHASED, AEM'S 12 MONTH LIMITED WARRANTY (WHICH CAN BE FOUND AT <https://www.aemelectronics.com/about-us/warranty-returns>, ALL AEM PRODUCTS ARE PROVIDED "AS IS" AND THE AEM PARTIES EXPRESSLY DISCLAIM ALL WARRANTIES, WHETHER EXPRESS, IMPLIED, STATUTORY OR OTHERWISE. THE AEM PARTIES SPECIFICALLY DISCLAIM ALL IMPLIED WARRANTIES OF MERCHANTABILITY AND FITNESS FOR A PARTICULAR PURPOSE, AND ALL WARRANTIES ARISING FROM COURSE OF DEALING, COURSE OF PERFORMANCE, USAGE OR TRADE PRACTICE. UNDER NO CIRCUMSTANCES SHALL ANY AEM PARTY BE LIABLE TO YOU OR ANY OTHER PERSON OR ENTITY FOR ANY DAMAGES OF ANY AMOUNT OR CHARACTER (INCLUDING, WITHOUT LIMITATION, ANY GENERAL, INDIRECT, SPECIAL, INCIDENTAL, EXEMPLARY, CONSEQUENTIAL OR PUNITIVE DAMAGES) ARISING OUT OF, RELATED TO, OR IN CONNECTION WITH (1) YOUR INSTALLATION OF ANY AEM PRODUCTS OR (2) YOUR MISUSE OF ANY AEM PRODUCTS. IN NO EVENT SHALL ANY AEM PARTY BE LIABLE TO YOU OR ANY OTHER PERSON OR ENTITY FOR ANY LOST OR CORRUPTED DATA, LOST PROFITS, LOST REVENUES, LOSS OF USE, DIMINUTION IN VALUE, LOSS OF OTHER INTANGIBLES OR ANY SPECIAL, INCIDENTAL, INDIRECT, EXEMPLARY, PUNITIVE OR CONSEQUENTIAL DAMAGES, WHETHER ARISING OUT OF BREACH OF CONTRACT, TORT (INCLUDING NEGLIGENCE) OR OTHERWISE, REGARDLESS OF WHETHER SUCH DAMAGES WERE FORESEEABLE AND WHETHER OR NOT THE AEM PARTIES WERE ADVISED OF THE POSSIBILITY OF SUCH DAMAGES. SOME JURISDICTIONS MAY NOT ALLOW THE EXCLUSION OR LIMITATION OF INCIDENTAL OR CONSEQUENTIAL DAMAGES, SO THE ABOVE EXCLUSIONS SHALL ONLY APPLY TO THE EXTENT PERMISSIBLE UNDER APPLICABLE LAW.

Introduction

This low voltage harness assembly was designed to be installed in the front half of the electric vehicle. It was designed to be used with a mating rear half assembly that is VCU hardware specific. The AEM part number for the mating rear half harness is 30-8601.

Connector interface features include:

- AEM VCU275 (VCU)
- Battery Management System – Master (BMS)
- Power Distribution Unit (PDU)
- Main Relay (MAIN RELAY)
- Fuse (FUSE)
- VC275 Power Flying Lead (VCU POWER)
- 12V Battery Flying Leads (12V BATT)
- Wake Switch Flying Lead (WAKE)
- Accelerator Pedal Position Flying Leads (APP)
- Brake Flying Leads (Brake)
- Heater Flying Lead (HEATER)
- Insulation Monitoring Device Lead (IMD)
- DB9 Communications Port (COMMS)
- CAN2 (CAN2)
- CAN3 (CAN3)
- AEM Keypad (KEYPAD)
- AEM Dash (DASH)
- Inline Signals (INLINE SIGNAL)
- Inline CAN (INLINE CAN)

Kit Content

- PN:10-1008 - QR Code Sheet for instructions
- PN: 5500009 - EGIS Relay
- Ring Terminals - USED FOR EGIS Relay studs
 - o PN:5100214 – 18-22AWG #1/4 CRIMP
 - o PN:5100215 – 14-16AWG #1/4 CRIMP
 - o PN:5100216 – 10-12AWG #1/4 CRIMP
 - o PN:5100217 - 6AWG #1/4 CRIMP
 - o PN:5100218 - 8AWG #1/4 CRIMP
- PN: 4-4025 - FUSE 20A x1
- PN: 8400012 - FUSE 3A x1
- PN: 4-1094 - CAN Terminating Resistors (120Ω)

TOLERANCE: ± 1.0in

Harness Layout

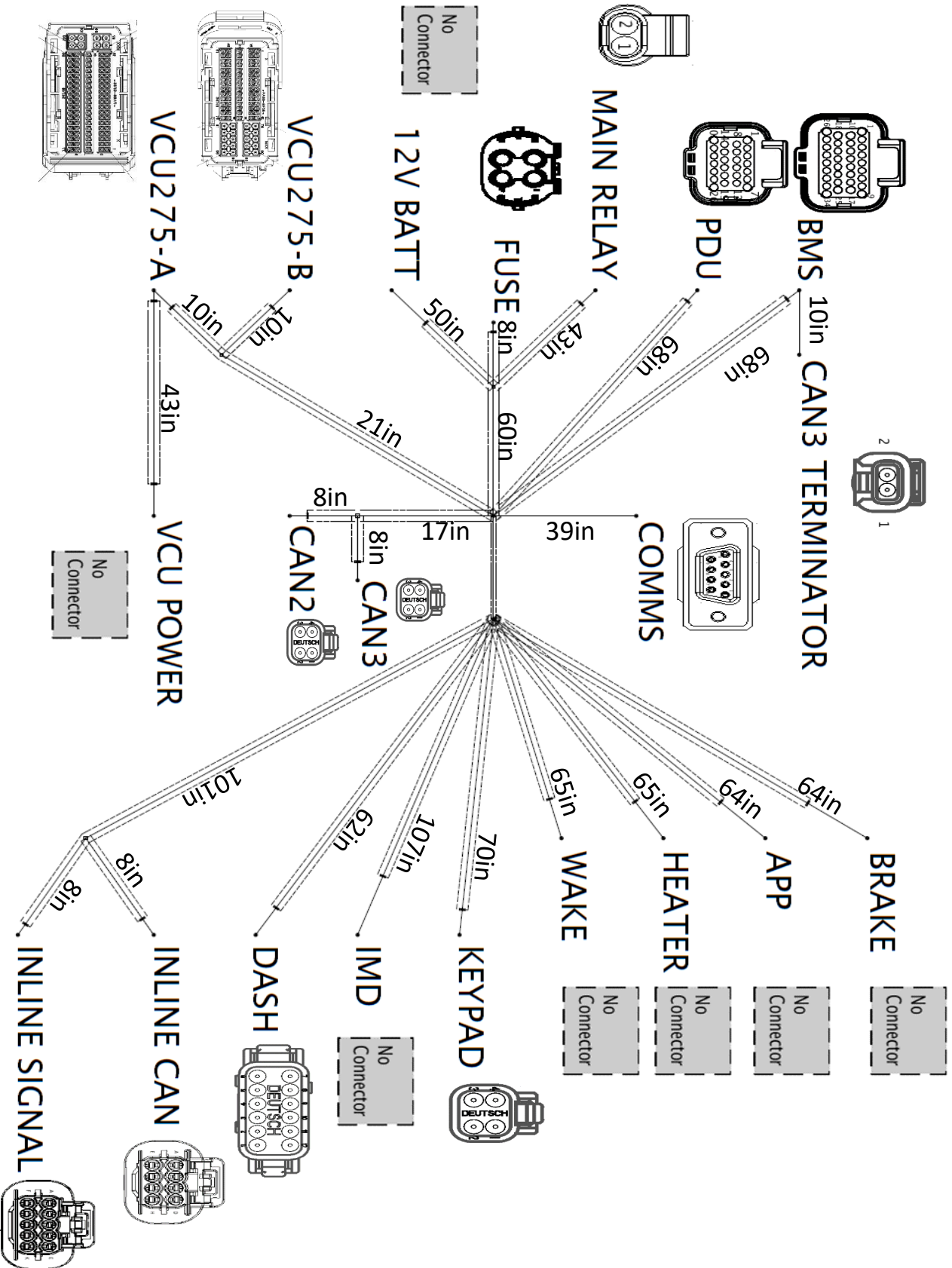

Harness Schematic

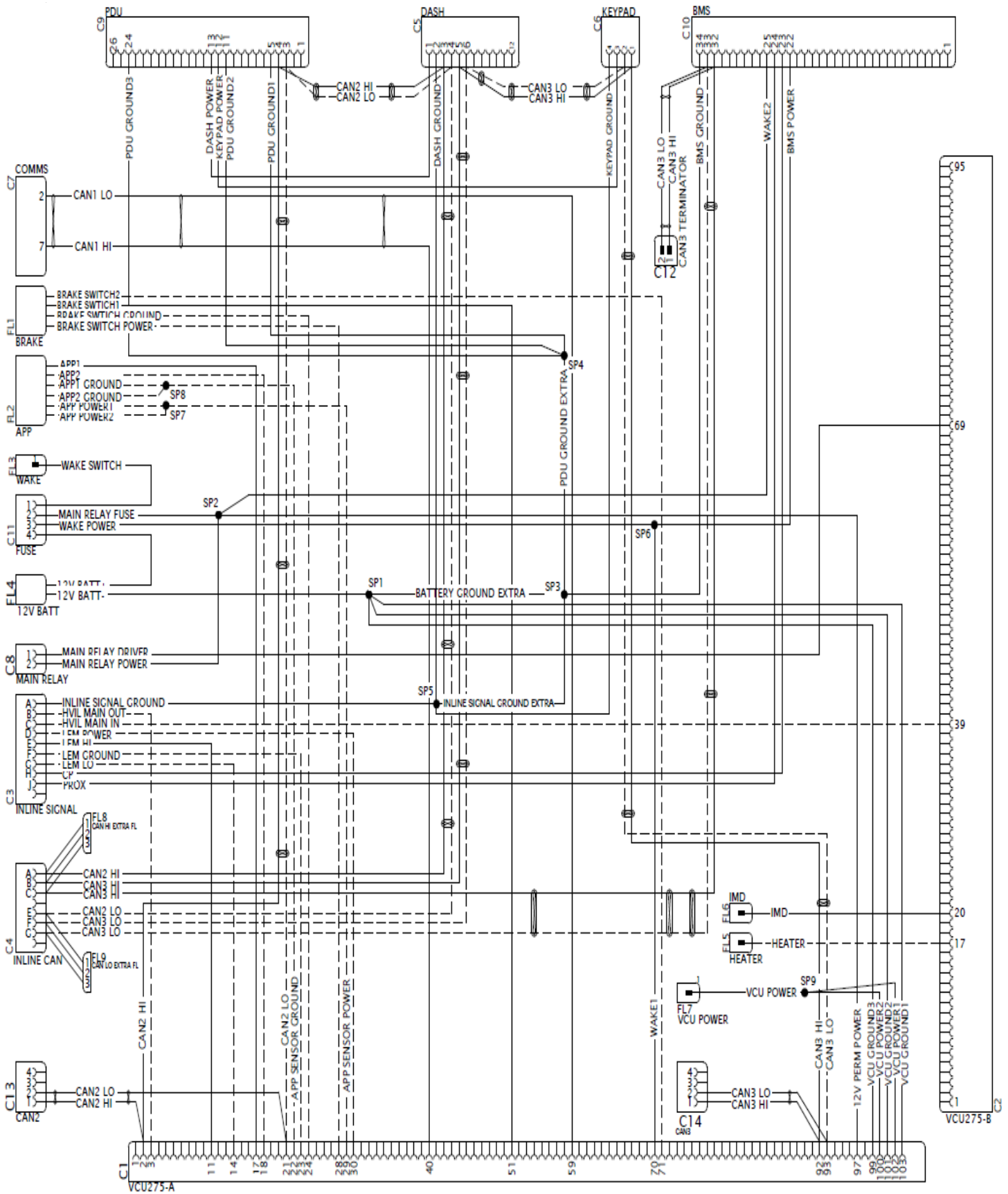

Harness Pinout

36-8604- VCU 275 Layover Harness

C1 Pin	VCU275 - A					Description GPEC4 RCPT CONN TOP LVR 103CKT KEY5/103
	Wire Color	Gauge	Destination			
			1	2	3	
C1-1						
C1-2	WHITE	24	C9-4	C13-1		CAN2 HI
C1-3	ORANGE/RED	20	C1-3			HVIL MAIN OUT
C1-4						
C1-5						
C1-6						
C1-7						
C1-8						
C1-9						
C1-10						
C1-11	BROWN	20	C1-11			LEM HI
C1-12						
C1-13						
C1-14	BROWN/WHITE	20	C1-14			LEM LO
C1-15						
C1-16						
C1-17	LIGHT GREEN	20	C1-17			APP1
C1-18	LIGHT GREEN/WHITE	20	C1-18			APP2
C1-19						
C1-20						
C1-21	WHITE/BLUE/GREEN	24	C9-3	C13-2		CAN2 LO
C1-22	BLACK/WHITE	20	FL2			APP SENSOR GROUND
C1-23	BLACK/WHITE	20	C3-F			LEM GROUND
C1-24	BLACK/WHITE	20	FL1			BRAKE SWITCH GROUND
C1-25						
C1-26						
C1-27						
C1-28	RED/WHTE	20	FL1			BRAKE SWITCH POWER
C1-29	RED/WHTE	20	FL2			APP SENSOR POWER
C1-30	RED/WHTE	20	C3-D			LEM POWER
C1-31						
C1-32						
C1-33						
C1-34						

C1-35					
C1-36					
C1-37					
C1-38					
C1-39					
C1-40	WHITE	24	C7-7		CAN1 HI
C1-41					
C1-42					
C1-43					
C1-44					
C1-45					
C1-46					
C1-47					
C1-48					
C1-49					
C1-50					
C1-51	LIGHT BLUE	20	FL1		BRAKE SWITCH1
C1-52					
C1-53					
C1-54					
C1-55					
C1-56					
C1-57					
C1-58					
C1-59	GREEN	24	C7-2		CAN1 LO
C1-60					
C1-61					
C1-62					
C1-63					
C1-64					
C1-65					
C1-66					
C1-67					
C1-68					
C1-69					
C1-70	RED	20	SP6		WAKE1
C1-71	LIGHT BLUE/WHITE	20	FL1		BRAKE SWTICH2
C1-72					
C1-73					
C1-74					

C1-75						
C1-76						
C1-77						
C1-78						
C1-79						
C1-80						
C1-81						
C1-82						
C1-83						
C1-84						
C1-85						
C1-86						
C1-87						
C1-88						
C1-89						
C1-90						
C1-91						
C1-92	WHITE	22	C6-1	C14-1		CAN3 HI
C1-93	WHITE/BLUE/GREEN	22	C6-2	C14-2		CAN3 LO
C1-94						
C1-95						
C1-96						
C1-97	RED	16	SP2			12V PERM POWER
C1-98						
C1-99	BLACK	16	SP1			VCU GROUND3
C1-100	RED	16	SP9			VCU POWER2
C1-101	BLACK	16	SP1			VCU GROUND2
C1-102	RED	16	SP9			VCU POWER1
C1-103	BLACK	16	SP1			VCU GROUND1

C2	VCU 275 - B					Description
Pin	Wire Color	Gauge	Destination			GPEC4 RCPT CONN KEY 5/95 95CKT TOP LVR
			1	2	3	
C2-1						
C2-2						
C2-3						
C2-4						
C2-5						
C2-6						

C2-7					
C2-8					
C2-9					
C2-10					
C2-11					
C2-12					
C2-13					
C2-14					
C2-15					
C2-16					
C2-17	RED/WHITE	20	FL5		HEATER
C2-18					
C2-19					
C2-20	PINK	20	FL6		IMD
C2-21					
C2-22					
C2-23					
C2-24					
C2-25					
C2-26					
C2-27					
C2-28					
C2-29					
C2-30					
C2-31					
C2-32					
C2-33					
C2-34					
C2-35					
C2-36					
C2-37					
C2-38					
C2-39	ORANGE/BLACK	20	C4-C		HVIL MAIN IN
C2-40					
C2-41					
C2-42					
C2-43					
C2-44					
C2-45					
C2-46					

C2-47					
C2-48					
C2-49					
C2-50					
C2-51					
C2-52					
C2-53					
C2-54					
C2-55					
C2-56					
C2-57					
C2-58					
C2-59					
C2-60					
C2-61					
C2-62					
C2-63					
C2-64					
C2-65					
C2-66					
C2-67					
C2-68					
C2-69	RED	20	C2-69		MAIN RELAY DRIVER
C2-70					
C2-71					
C2-72					
C2-73					
C2-74					
C2-75					
C2-76					
C2-77					
C2-78					
C2-79					
C2-80					
C2-81					
C2-82					
C2-83					
C2-84					
C2-85					
C2-86					

C2-87						
C2-88						
C2-89						
C2-90						
C2-91						
C2-92						
C2-93						
C2-94						
C2-95						

C3	INLINE SIGNALS					Description
Pin	Wire Color	Gauge	Destination			10 Way 1.5 GT 150 Sealed
			1	2	3	
C3-A	BLACK	16	SP5			INLINE SIGNAL GROUND
C3-B	ORANGE/RED	20	C1-3			HVIL MAIN OUT
C3-C	ORANGE/BLACK	20	C2-39			HVIL MAIN IN
C3-D	RED/WHITE	20	C1-30			LEM POWER
C3-E	BROWN	20	C1-11			LEM HI
C3-F	BLACK/WHITE	20	C1-23			LEM GROUND
C3-G	BROWN/WHITE	20	C1-14			LEM LO
C3-H	GREEN	20	C10-23			CP
C3-J	BLUE	20	C10-24			PROX
C3-K						

C4	Inline CAN					Description
Pin	Wire Color	Gauge	Destination			8 Way 1.5 GT 150 Sealed
			1	2	3	
C4-A	WHITE	24	C5-3			CAN2 HI
C4-B	WHITE	24	C5-5			CAN3 HI
C4-C	WHITE	24	C10-32			CAN3 HI
C4-D						
C4-E	WHITE/BLUE	24	C5-4			CAN2 LO
C4-F	WHITE/BLUE	24	C5-6			CAN3 LO
C4-G	WHITE/BLUE	24	C10-33			CAN3 LO
C4-H						

C5	DASH					Description
Pin	Wire Color	Gauge	Destination			12P SZ 20 DTM PLUG
			1	2	3	
C5-1	RED	20	C9-13			DASH POWER
C5-2	BLACK	20	SP5			DASH GROUND
C5-3	WHITE	24	C4-A	C9-4		CAN2 HI
C5-4	WHITE/BLUE	24	C4-E	C9-3		CAN2 LO
C5-5	WHITE	24	C4-B	C6-1		CAN3 HI
C5-6	WHITE/BLUE	24	C4-F	C6-2		CAN3 LO
C5-7						
C5-8						
C5-9						
C5-10						
C5-11						
C5-12						

C6	KEYPAD					Description
Pin	Wire Color	Gauge	Destination			4P SZ 20 DTM PLUG GREY
			1	2	3	
C6-1	WHITE	20	C4-B	C5-5		CAN3 HI
C6-2	WHITE/BLUE	20	C4-F	C5-6		CAN3 LO
C6-3	RED	20	C9-12			KEYPAD POWER
C6-4	BLACK	20	SP5			KEYPAD GROUND

C7	COMMS					Description
Pin	Wire Color	Gauge	Destination			DB9
			1	2	3	
C7-1						
C7-2	GREEN	24	C1-59			CAN1 LO
C7-3						
C7-4						
C7-5						
C7-6						
C7-7	WHITE	24	C1-40			CAN1 HI
C7-8						
C7-9						

C8	MAIN RELAY					Description
Pin	Wire Color	Gauge	Destination			4POS, MCON 1.2 CB REC 2p TL SEALED
			1	2	3	
C8-1	PINK	20	C2-69			MAIN RELAY DRIVER
C8-2	RED	20	SP2			MAIN RELAY POWER

C9	PDU					Description
Pin	Wire Color	Gauge	Destination			26POS,SUPERSEAL,REC HSG ASSY,SLD,COD 1
			1	2	3	
C9-1						
C9-2						
C9-3	WHITE/BLUE	24	C1-21	C5-4		CAN2 LO
C9-4	WHITE	24	C1-2	C5-3		CAN2 HI
C9-5	BLACK	20	SP4			PDU GROUND1
C9-6						
C9-7						
C9-8						
C9-9						
C9-10						
C9-11	BLACK	20	SP4			PDU GROUND2
C9-12	RED	20	C6-3			KEYPAD POWER
C9-13	RED	20	C5-1			DASH POWER
C9-14						
C9-15						
C9-16						
C9-17						
C9-18						
C9-19						
C9-20						
C9-21						
C9-22						
C9-23						
C9-24	BLACK	20	SP4			PDU GROUND3
C9-25						
C9-26						

C10	BMS					Description
Pin	Wire Color	Gauge	Destination			34POS,SUPERSEAL,REC HSG ASSY,SLD,COD 1
			1	2	3	
C10-1						
C10-2						
C10-3						
C10-4						
C10-5						
C10-6						
C10-7						
C10-8						
C10-9						
C10-10						
C10-11						
C10-12						
C10-13						
C10-14						
C10-15						
C10-16						
C10-17						
C10-18						
C10-19						
C10-20						
C10-21						
C10-22	RED	20	SP6			WAKE 2
C10-23	GREEN	20	C3-H			CP
C10-24	BLUE	20	C3-J			PROX
C10-25	RED	20	SP2			BMS POWER
C10-26						
C10-27						
C10-28						
C10-29						
C10-30						
C10-31						
C10-32	WHITE	24	C4-C	C12-1		CAN3 HI
C10-33	WHITE/BLUE	24	C4-G	C12-2		CAN3 LO
C10-34	BLACK	20	SP3			BMS GROUND

C11	FUSE					Description
Pin	Wire Color	Gauge	Destination			2 POS MINI FUSE BOX ASSY
			1	2	3	
C11-1	RED	20	FL3			WAKE SWITCH
C11-2	RED	16	SP2			MAIN RELAY FUSE
C11-3	RED	20	SP6			WAKE POWER
C11-4	RED	16	FL4			12V BATT +

C12	CAN3 TERMINATOR					Description
Pin	Wire Color	Gauge	Destination			DTM 2 Way Plug
			1	2	3	
C12-1	WHITE	22	C10-32			CAN3 HI
C12-2	GREEN	22	C10-33			CAN3 LO

C13	CAN2 TAP					Description
Pin	Wire Color	Gauge	Destination			DTM 4 Way Plug
			1	2	3	
C13-1	WHITE	22	C1-2			CAN2 HI
C13-2	GREEN	22	C1-21			CAN2 LO
C13-3						
C13-4						

C14	CAN3 TAP					Description
Pin	Wire Color	Gauge	Destination			DTM 4 Way Plug
			1	2	3	
C14-1	WHITE	22	C1-92			CAN4 HI
C14-2	GREEN	22	C1-93			CAN4 LO
C14-3						
C14-4						

FL1	BRAKE					Description
Pin	Wire Color	Gauge	Destination			flying leads
			1	2	3	
	LIGHT BLUE	20	C1-51			BRAKE SWITCH 1
	BLACK/WHITE	20	C1-24			BRAKE SWITCH GROUND
	LIGHT BLUE/WHITE	20	C1-71			BRAKE SWITCH 2
	RED/WHITE	20	C1-28			BRAKE SWITCH POWER

FL2	APP					Description
Pin	Wire Color	Gauge	Destination			flying leads
			1	2	3	
	LIGHT GREEN	20	C1-17			APP1
	LIGHT GREEN/WHITE	20	C1-18			APP2
	BLACK/WHITE	20	SP8			APP GROUND 1
	BLACK/WHITE	20	SP8			APP GROUND 2
	RED/WHITE	20	SP7			APP POWER 1
	RED/WHITE	20	SP7			APP POWER 2

FL3	WAKE					Description
Pin	Wire Color	Gauge	Destination			flying leads
			1	2	3	
	RED	20	C11-1			WAKE SWITCH

FL4	12V BATT					Description
Pin	Wire Color	Gauge	Destination			flying leads
			1	2	3	
	RED	16	C11-4			12V BATT+
	BLACK	16	SP1			12V BATT-

FL5	HEATER					Description
Pin	Wire Color	Gauge	Destination			flying leads
			1	2	3	
	RED/WHITE	20	C2-17			HEATER

FL6	IMD					Description
Pin	Wire Color	Gauge	Destination			flying leads
			1	2	3	
	PINK	20	C2-20			IMD

FL7	VCU POWER					Description
Pin	Wire Color	Gauge	Destination			flying leads
			1	2	3	
	RED	16	SP9			VCU POWER

SP1	BATTERY GROUND					Description
Pin	Wire Color	Gauge	Destination			splice
			1	2	3	
	BLACK	16	FL4			12V BATT-
	BLACK	16	SP3			BATTERY GROUND EXTRA
	BLACK	16	C1-103			VCU GROUND1
	BLACK	16	C1-101			VCU GROUND2
	BLACK	16	C1-99			VCU GROUND3

SP2	PERM POWER					Description
Pin	Wire Color	Gauge	Destination			splice
			1	2	3	
	RED	20	C8-2			MAIN RELAY POWER
	RED	20	C11-2			MAIN RELAY FUSE
	RED	20	C10-25			BMS POWER
	RED	20	C1-97			PERM POWER

SP3	BMS GROUND					Description
Pin	Wire Color	Gauge	Destination			splice
			1	2	3	
	BLACK	16	SP1			BATTERY GROUND EXTRA
	BLACK	16	SP5			INLINE SIGNAL GROUND EXTRA
	BLACK	16	SP4			PDU GROUND EXTRA
	BLACK	20	C10-34			BMS GROUND

SP4	PDU GROUND					Description
Pin	Wire Color	Gauge	Destination			splice
			1	2	3	
	BLACK	20	C9-5			PDU GROUND 1
	BLACK	20	C9-11			PDU GROUND 2
	BLACK	20	C9-24			PDU GROUND 3
	BLACK	16	SP3			PDU GROUND EXTRA

SP5	INLINE SIGNAL GROUND					Description
Pin	Wire Color	Gauge	Destination			splice
			1	2	3	
	BLACK	16	C3-1			INLINE SIGNAL GROUND
	BLACK	20	C6-3			KEYPAD GROUND
	BLACK	20	C5-2			DASH GROUND
	BLACK	16	SP3			INLINE SIGNAL GROUND EXTRA

SP6	WAKE					Description
Pin	Wire Color	Gauge	Destination			splice
			1	2	3	
	RED	20	C11-3			WAKE POWER
	RED	20	C1-70			WAKE 1
	RED	20	C10-22			WAKE 2

SP7	APP POWER					Description
Pin	Wire Color	Gauge	Destination			splice
			1	2	3	
	RED/WHITE	20	C1-29			APP SENSOR POWER
	RED/WHITE	20	FL2			APP POWER1
	RED/WHITE	20	FL2			APP POWER2

SP8	APP GROUND					Description
Pin	Wire Color	Gauge	Destination			splice
			1	2	3	
	BLACK/WHITE	20	C1-22			APP SENSOR GROUND
	BLACK/WHITE	20	FL2			APP GROUND1
	BLACK/WHITE	20	FL2			APP GROUND2

SP9	VCU POWER					Description
Pin	Wire Color	Gauge	Destination			splice
			1	2	3	
	RED	16	FL7			VCU POWER
	RED	16	C1-102			VCU POWER1
	RED	16	C1-100			VCU POWER2

Harness Installation Tips

36-8601 CONNECTORS	INFORMATION & RECOMMENDED LOCATION
<p>C1 (VCU275-A) MOLEX: 34993-9001</p> 	<ul style="list-style-type: none"> - MATE: AEM VCU275 Part Number: 30-8400 - RECOMMENDED LOCATION: Front of the vehicle
<p>C2 (VCU275-B) MOLEX: 34992-9001</p> 	<ul style="list-style-type: none"> - MATE: AEM VCU275 Part Number: 30-8400 - RECOMMENDED LOCATION: Front of the vehicle
<p>C3 (INLINE SIGNALS) Aptiv 15326842</p> 	<ul style="list-style-type: none"> - MATE: AEM REAR LOW VOLTAGE VCU HARNESS Part Number: 30-8601 - RECOMMENDED LOCATION: As required

C4 (INLINE CAN)
Aptiv 15326835

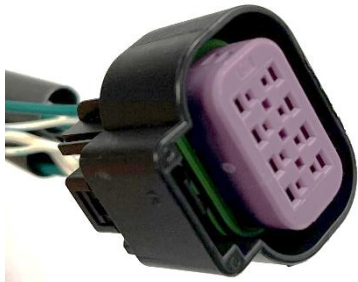

- MATE: AEM REAR LOW VOLTAGE VCU Harness
Part Number: 30-8601
- RECOMMENDED LOCATION: As required

C5 (DASH)
TE CONNECTIVITY: DTM06-12SA

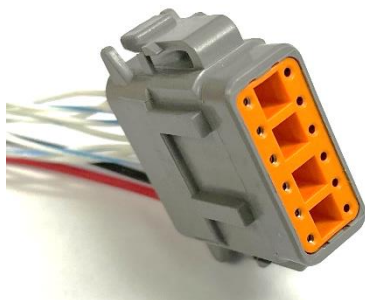

- MATE: AEM CD-7 Carbon Digital Dash Display
Part Number: 30-5700, 30-5701, 30-5702, 30-5703
Part Number: 30-5700F, 30-5701F, 30-5702F, 30-5703F
- MATE: AEM CD-5 Carbon Digital Dash Displays
Part Number: 30-5600, 30-5601, 30-5602, 30-5603
Part Number: 30-5600F, 30-5601F, 30-5602F, 30-5603F
- RECOMMENDED LOCATION: As required

C6 (KEYPAD)
TE CONNECTIVITY: DTM06-4S



- MATE: AEM EV 8-Button CAN Keypad
Part Number: 30-8400
- RECOMMENDED LOCATION: As required

<p>C7 (COMMS) AEM PN: 4-0146</p> 	<ul style="list-style-type: none"> - MATE: DB9 PORT - RECOMMENDED LOCATION: As required -
<p>C8 (MAIN RELAY) TE CONNECTIVITY: 282080-1</p> 	<ul style="list-style-type: none"> - MATE: AEM EGIS RELAY PART NUMBER: 5500009 - RECOMMENDED LOCATION: As required
<p>C9 (PDU) TE CONNECTIVITY: 3-1437290-7</p> 	<ul style="list-style-type: none"> - MATE: AEM POWER DISTRIBUTION UNIT (PDU-8) Part Number: 30-8300 - RECOMMENDED LOCATION: As required - NOTES: Installer responsible for adding power leads from PDU-8 to 12 volt loads. -

C10 (BMS)
TE CONNECTIVITY: 4-1437290-0



- MATE: AEM Battery Management Systems – Master Part Number: 30-8401M

C11 (FUZE)
TE Connectivity: 2066046-4





- MATE: N/A
- RECOMMENDED LOCATION: As required
- NOTES: PIN 1&3: 3A
PIN 2&4: 20A

C12 (CAN3 TERMINATOR)
TE Connectivity: DTM04-2P

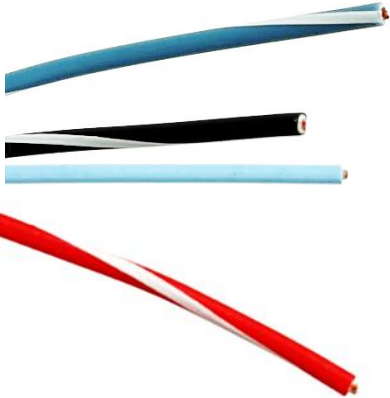

- MATE: AEM TERMINATING RESISTOR
PART NUMBER: 4-1094

<p>C13 (CAN2) TE Connectivity: DTM04-2P</p> 	<ul style="list-style-type: none"> - MATE: AEM AEMNET CAN HUB - PART NUMBER: 30-2225 - RECOMMENDED LOCATION: As required - NOTES:
<p>C14 (CAN3) TE Connectivity: DTM04-2P</p> 	<ul style="list-style-type: none"> - MATE: AEM AEMNET CAN HUB - PART NUMBER: 30-2225 - RECOMMENDED LOCATION: As required - NOTES:
<p>FL1 (BRAKE)</p> 	<ul style="list-style-type: none"> - MATE: Refer to the schematic on page 4

FL 2(APP)

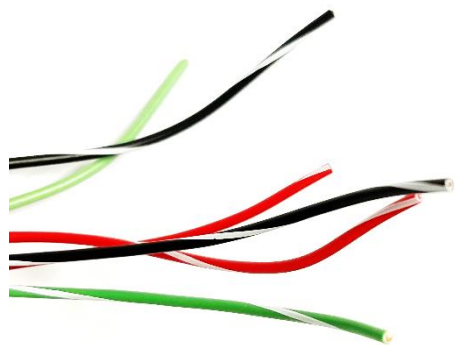

- MATE: Refer to the schematic on page 4

FL 3(WAKE SWITCH)





- MATE: Refer to the schematic on page 4

FL 4(12V BATT)

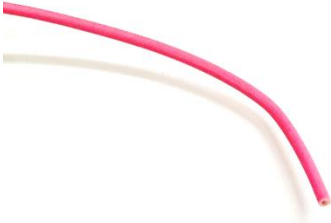

- MATE: Refer to the schematic on page 4

<p>FL 5(HEATER)</p> 	<ul style="list-style-type: none"> - MATE: Refer to the schematic on page 4
<p>FL 6(IMD)</p> 	<ul style="list-style-type: none"> - MATE: Bender IR155 03/04
<p>FL 7(VCU POWER)</p> 	<ul style="list-style-type: none"> - MATE: Refer to the schematic on page 4

CAN TERMINATING RESISTORS
AEM: 4-1094



- MATE: AEM EV VARIOUS HARNESESSES
- RECOMMENDED LOCATION: As required
- NOTES:120Ω Resistor

Warranty

AEM Performance Electronics warrants to the consumer that all AEM Electronics products will be free from defects in material and workmanship for a period of twelve months from the date of the original purchase. Products that fail within this 12-month warranty period will be repaired or replaced when determined by us that the product failed due to defects in material or workmanship. This warranty is limited to the repair or replacement of the AEM Electronics part. This warranty applies only to the original purchaser of the product and is nontransferable. All implied warranties shall be limited in duration to the said 12-month warranty period. Improper use or installation, accident, abuse, unauthorized repairs, or alterations performed by the user on any AEM Electronics products voids this warranty.

In no event shall this warranty exceed the original purchase price of the AEM Electronics part nor shall AEM Electronics be responsible for special, incidental, or consequential damages or cost incurred due to the failure of this product.

AEM Electronics disclaims any liability for consequential damages due to breach of any written or implied warranty on all of its products.

Warranty returns will only be accepted by AEM Electronics when accompanied by a valid Return Merchandise Authorization (RMA) number and a dated proof of purchase. The product must be received by AEM Electronics within 30 days of the date the RMA is issued. Warranty claims to AEM Electronics must be shipped to us prepaid (we recommend a shipping service with package tracking capability). Once your package is received by our warranty and repairs department you will be notified and provided with updates.

PROCEDURES FOR ISSUANCE OF A RETURN MERCHANDISE AUTHORIZATION (RMA) NUMBER

Please note that before AEM Electronics can issue an RMA for any product, it is first necessary for the installer or end-user to contact our technical support team to discuss the problem. Most issues can be resolved over the phone. Under no circumstances should a system be returned, or an RMA requested before our support team is contacted. This will ensure that if an RMA is needed that our team is able to track your product through the warranty process.

You can reach our Tech Support Team for support on all AEM Electronics performance products by phone at 1-800-423-0046. To contact us by email for engine management systems, email us at emstech@aemelectronics.com. For all other products, email us at gen.tech@aemelectronics.com.

AEM Electronics will not be responsible for products that are installed incorrectly, installed in a non-approved application, misused, or tampered with. In the case of AEM Electronics Fuel Pumps, incorrect polarity (+&- wires crossed) will not be warranted. Proper fuel filtration before and after the fuel pump is essential to fuel pump life. Any pump returned with contamination will not be warranted.