



## INSTALLATION MANUAL:

*COR-5009200*

*COR-4809200*

*COR-5009300*

*COR-4809300*

JEEP WRANGLER JL LONG ARM UPGRADE  
KIT, OVERLAND+ AND PREMIUM SERIES

Fits 3.6 V6, 392 V8 HEMI, and 2.0 I4  
engine options.

# ATTENTION:

Please review the Long Arm Upgrade Kit Compatibility chart below.

Depending on what JL model you are planning to work on, please note that some component SKUs are used across all vehicle models, and some are specific to that model.

	LONG ARM UPGRADE KIT COMPATABILITY					
	JL 3.6L V6 / 2.0 I4		JL 392 6.4L V8		JL 3.0L V6 Eco-Diesel	
COMPONENTS	OVERLAND+	PREMIUM	OVERLAND+	PREMIUM	OVERLAND+	PREMIUM
COMPLETE UPGRADE KIT	5009200	4809200	5009300	4809300		
FRONT UPGRADE KIT	5009201	4809201	5009301	4809301		
FRONT BRACKETS	2209100		2209110			
FRONT UPPER ARMS	1709101	1809101	1709101	1809101		
FRONT LOWER ARMS	1909010	1909210	1909010	1909210		
REAR UPGRADE KIT	5009210	4809210	5009210	4809210		
REAR BRACKETS	2209200		2209200			
REAR UPPER ARMS	1909030	1909230	1909030	1909230		
REAR LOWER ARMS	1909020	1909220	1909020	1909220		

**COMING SOON**

# DISCLAIMER:

## WARNING:

Suspension systems and their components are designed to enhance your vehicle's off-road performance. This may cause your vehicle to handle differently, on and off-road. Always wear your seatbelt and take extra care when driving a modified vehicle. Failure to do so can result in loss of control which may result in a rollover causing serious injury, or even death to the driver and/or passengers of the vehicle. Regular maintenance and consistent inspections are required to keep your modified vehicle safe and functioning properly. These suspension systems and any components should be installed by certified technicians only. Attempts to install these products without proper knowledge can lead to poor performance, or possible failure, which may jeopardize the safety of the vehicle and its passengers. The installer is responsible for proper installation ensuring a safe and properly functioning vehicle. Take extra care when operating a modified vehicle and thoroughly inspect your vehicle before and after every off-road use.

Read the instruction set in its entirety before attempting the installation.

## NOTE:

This product may require general welding, fabrication, and automotive mechanic skills. Welding should only be done by a competent welder. Clayton Off Road implies no guarantees or warranties and is not liable for improper installation. Some grinding and fitment may be required when installing this product. Every vehicle varies slightly, and some fabrication and/or modification may be required.

## ATTENTION:

It is the customer's responsibility to thoroughly inspect all received parts to ensure they are assembled correctly and fully welded. Please carefully examine all weld seams and verify that bolt-through holes are properly aligned. Some Clayton Off Road products are permanent, non-removable, weld-on solutions. **If a defect or issue is found after installation, especially with permanent weld-on components, it may be difficult or impossible to correct.** Inspecting the part(s) received beforehand helps prevent unnecessary and avoidable complications.

## ATTENTION: TORQUE SPECIFICATION

When working on any vehicle, it is good practice to torque suspension/weight-bearing components while the vehicle is resting under its load. This instruction set, as well as any other Clayton Off Road instruction set, assumes the installer will tighten any suspension-related components properly, to the recommended torque specification, when the vehicle is resting safely under its own weight.

# CONTROL ARM OVERVIEW

\*\*\*Please review the following information so you can become familiar with our purchasable options\*\*\*



## OVERLAND PLUS

Designed for the daily driver/weekend warrior. Features dual-durometer, maintenance-free bushings for comfort on-road and capability on the trails. One of our two available suspension systems that utilize a unique long arm design for perfecting suspension geometry. Fully adjustable, 100% bolt on, and Made-In-The-USA with a Lifetime Warranty.



## PREMIUM SERIES

Designed for the off-road enthusiast. Features both maintenance-free bushings and forged Johnny Joint adjusters for maximum versatility and flex. One of our two available suspension systems that utilize a unique long arm design for perfecting suspension geometry. Fully adjustable, 100% bolt on, and Made-In-The-USA with a Lifetime Warranty.

\*\*\*Arms, frame brackets, and hardware are identical, meaning you can swap to a different series at any point\*\*\*

# FRONT SUSPENSION COMPONENTS

\*\*\*Please review the part numbers you have purchased to familiarize yourself with the product(s)\*\*\*



# 5009201 - INCLUDED ITEMS

5009201 Jeep Wrangler FRONT Overland+ 3.6 V6 Long Arm Upgrade Kit (2018+, JL/JT)				
QTY	Part Number	Description	Class/Grade	ID Number
1	2209100	Jeep Front Left/Right Long Arm Frame Brackets	N/A	1
1	1909010	Jeep Overland+ Long Front Lower Control Arms	N/A	2
1	1709101	Jeep Overland+ Short Front Upper Control Arms	N/A	3
2	18968	5/8"-18 x 4" Zinc Finish Hex Cap Screw	Grade 8	4
4	33819	5/8" x 1.312" OD Zinc Finish Flat Washer	N/A	5
2	37312	5/8"-18 Zinc Finish Top Lock Nut	Grade C	6
2	0128794	M12-1.75 x 80mm Zinc Finish Hex Cap Screw	Class 10.9	7
4	11103710	M12 x 24mm Zinc Finish Flat Washer	Grade HV200	8
2	90683	M12-1.75 DIN 980 Zinc Finish Top Lock Nut	Class 10	9
2	11114711	M12-1.50 x 110mm Zinc Finish Hex Cap Screw	Class 10.9	5
4	11103710	M12-1.5 Zinc Finish Flat Washer	Grade HV200	6
2	0145171	M12-24mm OD Zinc Finish Top Lock Nut	Class 8	7
1	32448	5/16"-18 x 3/4" Hex Unslotted Self-Tapping Screw	N/A	8

## Product Notes and Features:

- Weld-on frame brackets made of 1/4" thick steel construction
- Utilizes the factory axle mounting points, no axle modification required
- Reduced suspension angles for a smoother, more controlled ride
- Longer arms to deliver greater articulation and climbing ability
  - **Lower arm dimensions: MIN =  $37\frac{1}{16}$ " , MAX =  $38\frac{13}{16}$ " , INSTALL =  $37\frac{1}{2}$ "**
  - **Upper arm dimensions: MIN =  $19\frac{3}{4}$ " , MAX =  $21\frac{1}{8}$ " , INSTALL = 20"**
- GIIRO Joint bushings on the lower axle side and at the adjuster for smoother on-road handling, superior off-road articulation, and long-lasting reliability



# 4809201 - INCLUDED ITEMS

4809201 Jeep Wrangler FRONT Premium 3.6 V6 Long Arm Upgrade Kit (2018+, JL/JT)				
QTY	Part Number	Description	Class/Grade	ID Number
1	2209100	Jeep Front Left/Right Long Arm Frame Brackets	N/A	1
1	1909210	Jeep Premium Long Front Lower Control Arms	N/A	2
1	1809101	Jeep Premium Short Front Upper Control Arms	N/A	3
2	18968	5/8"-18 x 4" Zinc Finish Hex Cap Screw	Grade 8	4
4	33819	5/8" x 1.312" OD Zinc Finish Flat Washer	N/A	5
2	37312	5/8"-18 Zinc Finish Top Lock Nut	Grade C	6
2	0128794	M12-1.75 x 80mm Zinc Finish Hex Cap Screw	Class 10.9	7
4	11103710	M12 x 24mm Zinc Finish Flat Washer	Grade HV200	8
2	90683	M12-1.75 DIN 980 Zinc Finish Top Lock Nut	Class 10	9
2	11114711	M12-1.50 x 110mm Zinc Finish Hex Cap Screw	Class 10.9	10
4	11103710	M12-1.5 Zinc Finish Flat Washer	Grade HV200	11
2	0145171	M12-24mm OD Zinc Finish Top Lock Nut	Class 8	12
1	32448	5/16"-18 x 3/4" Hex Unslotted Self-Tapping Screw	N/A	13

## Product Notes and Features:

- Weld-on frame brackets made of 1/4" thick steel construction
- Utilizes the factory axle mounting points, no axle modification required
- Reduced suspension angles for a smoother, more controlled ride
- Longer arms to deliver greater articulation and climbing ability
  - **Lower arm dimensions: MIN = 37  $\frac{1}{4}$ " , MAX = 38  $\frac{3}{16}$ " , INSTALL = 37  $\frac{1}{2}$ "**
  - **Upper arm dimensions: MIN = 19  $\frac{5}{8}$ " , MAX = 22  $\frac{1}{2}$ " , INSTALL = 20"**
- GIIRO Joint bushings on the axle end and Johnny Joints at the adjusters for superior off-road articulation, maximum versatility, and long-lasting reliability

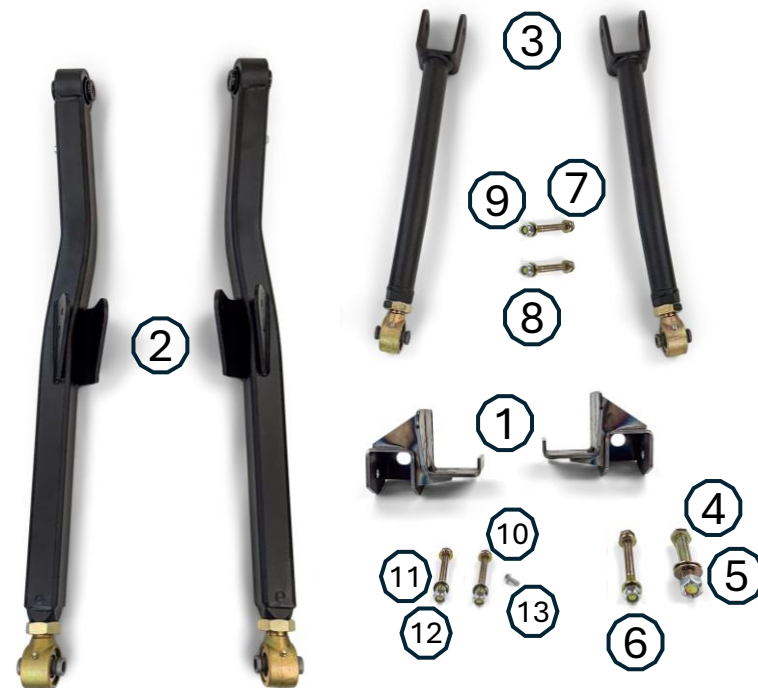

## 2209100 - INCLUDED ITEMS

2209100 Jeep Wrangler FRONT Long Arm Frame Brackets (2018+, JL/JT)				
QTY	Part Number	Description	Class/Grade	ID Number
1	2209100	Jeep Front Left/Right Long Arm Frame Brackets	N/A	1
2	18968	5/8"-18 x 4" Zinc Finish Hex Cap Screw	Grade 8	2
4	33819	5/8" x 1.312" OD Zinc Finish Flat Washer	N/A	3
2	37312	5/8"-18 Zinc Finish Top Lock Nut	Grade C	4
2	11114711	M12-1.50 x 110mm Zinc Finish Hex Cap Screw	Class 10.9	5
4	11103710	M12-1.5 Zinc Finish Flat Washer	Grade HV200	6
2	0145171	M12-24mm OD Zinc Finish Top Lock Nut	Class 8	7
1	32448	5/16"-18 x 3/4" Hex Unslotted Self-Tapping Screw	N/A	8

### Product Notes and Features:

The Jeep Wrangler Front Long Arm Frame Brackets (2018+, JL/JT) are designed to relocate the control arm mounting points for a long arm kit upgrade. Built tough and engineered for performance, these brackets are essential for achieving the improved geometry and handling that a long arm kit provides.

- Weld-on frame brackets made of 1/4" thick steel construction
- formed using the latest CAD software and manufacturing techniques
- Complete hardware kit included (comes with 5/8" bolts, washers, and nuts)
  - Comes with M12-1.5 x 110mm bolts, washers, and nuts for replacing the outer cross-member bolts if they were not swapped around
- Cutting and welding required
- Control arms not included



# 5009301 - INCLUDED ITEMS

5009301 Jeep Wrangler FRONT Overland+ 392 V8 HEMI Long Arm Upgrade Kit (2021+, JL)				
QTY	Part Number	Description	Class/Grade	ID Number
1	2209110	Jeep 392 Front Left/Right Long Arm Frame Brackets	N/A	1
1	1909010	Jeep Overland+ Long Front Lower Control Arms	N/A	2
1	1709101	Jeep Overland+ Short Front Upper Control Arms	N/A	3
2	18968	5/8"-18 x 4" Zinc Finish Hex Cap Screw	Grade 8	4
4	33819	5/8" x 1.312" OD Zinc Finish Flat Washer	N/A	5
2	37312	5/8"-18 Zinc Finish Top Lock Nut	Grade C	6
2	0128794	M12-1.75 x 80mm Zinc Finish Hex Cap Screw	Class 10.9	7
4	11103710	M12 x 24mm Zinc Finish Flat Washer	Grade HV200	8
2	90683	M12-1.75 DIN 980 Zinc Finish Top Lock Nut	Class 10	9

## Product Notes and Features:

- Weld-on frame brackets made of ¼" thick steel construction
- Utilizes the factory axle mounting points, no axle modification required
- Reduced suspension angles for a smoother, more controlled ride
- Longer arms to deliver greater articulation and climbing ability
  - **Lower arm dimensions: MIN = 37  $\frac{1}{16}$ " , MAX = 38  $\frac{13}{16}$ " , INSTALL = 37  $\frac{1}{2}$ "**
  - **Upper arm dimensions: MIN = 19  $\frac{3}{4}$ " , MAX = 21  $\frac{1}{8}$ " , INSTALL = 20"**
- GIIRO Joint bushings on the lower axle side and at the adjuster for smoother on-road handling, superior off-road articulation, and long-lasting reliability
- No exhaust modification necessary for the 392 JL 2021+
- Currently tested and confirmed on a 392 V8 HEMI JL ONLY!



**392**  
**HEMI**

# 4809301 - INCLUDED ITEMS

## 4809301 Jeep Wrangler FRONT Premium 392 V8 HEMI Long Arm Upgrade Kit (2021+, JL)

QTY	Part Number	Description	Class/Grade	ID Number
1	2209110	Jeep 392 Front Left/Right Long Arm Frame Brackets	N/A	1
1	1909210	Jeep Premium Long Front Lower Control Arms	N/A	2
1	1809101	Jeep Premium Short Front Upper Control Arms	N/A	3
2	18968	5/8"-18 x 4" Zinc Finish Hex Cap Screw	Grade 8	4
4	33819	5/8" x 1.312" OD Zinc Finish Flat Washer	N/A	5
2	37312	5/8"-18 Zinc Finish Top Lock Nut	Grade C	6
2	0128794	M12-1.75 x 80mm Zinc Finish Hex Cap Screw	Class 10.9	7
4	11103710	M12 x 24mm Zinc Finish Flat Washer	Grade HV200	8
2	90683	M12-1.75 DIN 980 Zinc Finish Top Lock Nut	Class 10	9

### Product Notes and Features:

- Weld-on frame brackets made of ¼" thick steel construction
- Utilizes the factory axle mounting points, no axle modification required
- Reduced suspension angles for a smoother, more controlled ride
- Longer arms to deliver greater articulation and climbing ability
  - **Lower arm dimensions: MIN = 37  $\frac{1}{4}$ " , MAX = 38  $\frac{3}{16}$ " , INSTALL = 37  $\frac{1}{2}$ "**
  - **Upper arm dimensions: MIN = 19  $\frac{5}{8}$ " , MAX = 22  $\frac{1}{4}$ " , INSTALL = 20"**
- GIIRO Joint bushings on the axle end and Johnny Joints at the adjusters for superior off-road articulation, maximum versatility, and long-lasting reliability
- No exhaust modification necessary for the 392 JL 2021+
- Currently tested and confirmed on a 392 V8 HEMI JL ONLY!

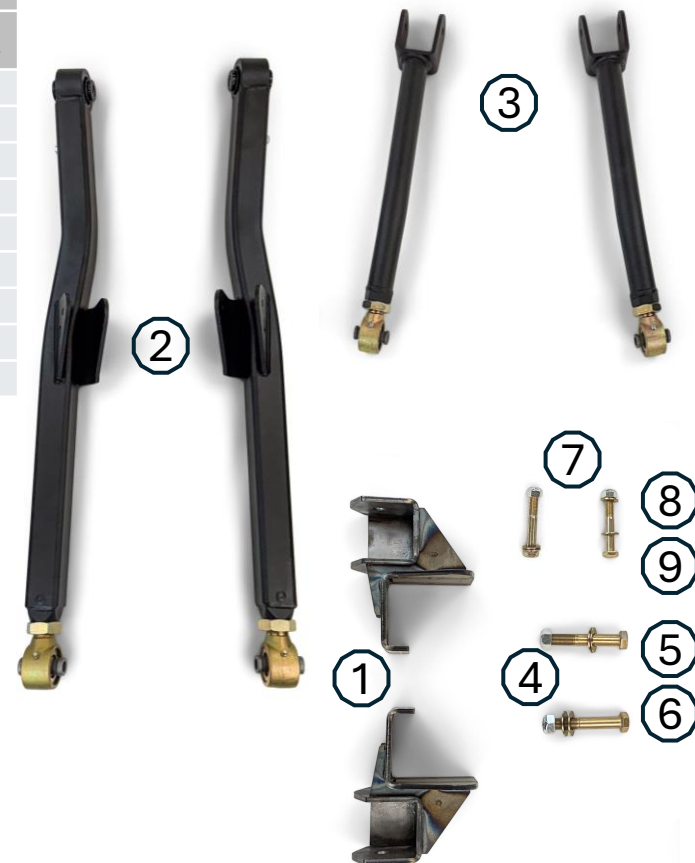

**392**  
**HEMI**

## 2209110 - INCLUDED ITEMS

2209110 Jeep Wrangler FRONT 392 V8 HEMI Long Arm Frame Brackets (2021+, JL)				
QTY	Part Number	Description	Class/Grade	ID Number
1	2209110	Jeep 392 Front Left/Right Long Arm Frame Brackets	N/A	1
2	18968	5/8"-18 x 4" Zinc Finish Hex Cap Screw	Grade 8	2
4	33819	5/8" x 1.312" OD Zinc Finish Flat Washer	N/A	3
2	37312	5/8"-18 Zinc Finish Top Lock Nut	Grade C	4

### Product Notes and Features:

The Jeep Wrangler Front 392 V8 HEMI Long Arm Frame Brackets (2021+, JL) are designed to relocate the control arm mounting points for a long arm kit upgrade. Built tough and engineered for performance, these brackets are essential for achieving the improved geometry and handling that a long arm kit provides.

- Weld-on frame brackets made of ¼" thick steel construction
- **Slightly modified design for proper clearance for 392 V8 HEMI exhaust**
- formed using the latest CAD software and manufacturing techniques
- Complete hardware kit included (comes with 5/8" bolts, washers, and nuts)
- Cutting and welding required
- Control arms not included
- Currently tested and confirmed on a 392 V8 HEMI JL ONLY!

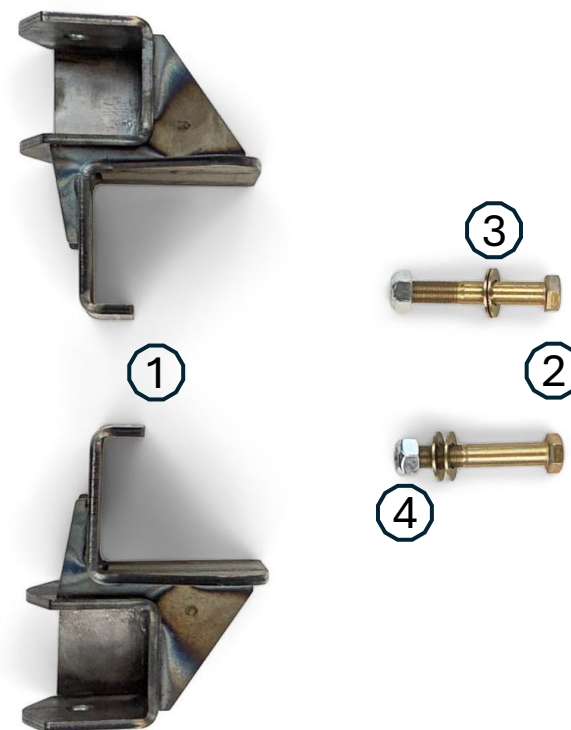

**392**  
**HEMI**

# 1709101 - INCLUDED ITEMS

1709101 Jeep Wrangler Overland+ FRONT Upper Control Arms (2018+, JL/JT)				
QTY	Part Number	Description	Class/Grade	ID Number
1	1709101	Jeep Overland+ Short Front Upper Control Arms	N/A	1

## Product Notes and Features:

Achieve superior performance and durability with the **Ultimate Jeep Control Arms**, engineered for unmatched comfort and reliability. Designed with meticulous attention to detail, these control arms are built to handle the toughest terrains while delivering a smooth and quiet driving experience.

- Maintenance-free, dual-durometer design isolates road noise and vibration for a quieter ride
- Self-centering with 26.6 degrees of total articulation, ensuring smooth suspension movement
- Heavy-duty DOM tubing for maximum strength and durability
- Forged adjusters for precise alignment and adjustability
- Bolt-in design resulting in an easy installation with no modifications required
- No hardware included
- **Arm dimensions: MIN = 19  $\frac{3}{4}$ " , MAX = 21  $\frac{1}{8}$ " , INSTALL = 20"**



# 1809101 - INCLUDED ITEMS

1809101 Jeep Wrangler Premium FRONT Upper Control Arms (2018+, JL/JT)				
QTY	Part Number	Description	Class/Grade	ID Number
1	1809101	Jeep Premium Short Front Upper Control Arms	N/A	1

## Product Notes and Features:

Achieve superior performance and durability with the **Ultimate Jeep Control Arms**, engineered for unmatched comfort and reliability. Designed with meticulous attention to detail, these control arms are built to handle the toughest terrains while delivering a smooth and quiet driving experience.

- Smooth and quiet performance that isolates road noise and vibration for a quieter ride
- Reliable, greaseable, and rebuildable joints with 40 degrees of misalignment
- Heavy-duty DOM tubing for maximum strength and durability
- Forged adjusters for precise alignment and adjustability
- Bolt-in design resulting in an easy installation with no modifications required
- No hardware included
- **Arm dimensions: MIN =  $19\frac{5}{8}$ " , MAX =  $22\frac{1}{4}$ " , INSTALL = 20"**



# 1909010 - INCLUDED ITEMS

1909010 Jeep Wrangler Overland+ Long FRONT Lower Control Arms (2018+, JL/JT)				
QTY	Part Number	Description	Class/Grade	ID Number
1	1909010	Jeep Overland+ Long Front Lower Control Arms	N/A	1
2	0128794	M12-1.75 x 80mm Zinc Finish Hex Cap Screw	Class 10.9	2
4	11103710	M12 x 24mm Zinc Finish Flat Washer	Grade HV200	3
2	90683	M12-1.75 DIN 980 Zinc Finish Top Lock Nut	Class 10	4

## Product Notes and Features:

Achieve superior performance and durability with the **Ultimate Jeep Control Arms**, engineered for unmatched comfort and reliability. Designed with meticulous attention to detail, these control arms are built to handle the toughest terrains while delivering a smooth and quiet driving experience.

- Maintenance-free, dual-durometer design isolates road noise and vibration for a quieter ride
- Self-centering with 26.6 degrees of total articulation, ensuring smooth suspension movement
- Heavy-duty square tubing and DOM housings for maximum strength and durability
- Forged adjusters for precise alignment and adjustability
- Reduced suspension angles for a smoother, more controlled ride
  - Only tested and confirmed use in conjunction with COR-2209100, Front Long Arm Brackets
- Longer arms to deliver greater articulation and climbing ability
- Radius arm hardware (M12 – 1.75 x 80mm bolts, nuts and washers) included
- **Arm dimensions: MIN =  $37\frac{1}{16}$ "**, **MAX =  $38\frac{13}{16}$ "**, **INSTALL =  $37\frac{1}{2}$ "**



# 1909210 - INCLUDED ITEMS

1909210 Jeep Wrangler Premium Long FRONT Lower Control Arms (2018+, JL/JT)				
QTY	Part Number	Description	Class/Grade	ID Number
1	1909210	Jeep Premium Long Front Lower Control Arms	N/A	1
2	0128794	M12-1.75 x 80mm Zinc Finish Hex Cap Screw	Class 10.9	2
4	11103710	M12 x 24mm Zinc Finish Flat Washer	Grade HV200	3
2	90683	M12-1.75 DIN 980 Zinc Finish Top Lock Nut	Class 10	4

## Product Notes and Features:

Achieve superior performance and durability with the **Ultimate Jeep Control Arms**, engineered for unmatched comfort and reliability. Designed with meticulous attention to detail, these control arms are built to handle the toughest terrains while delivering a smooth and quiet driving experience.

- Smooth and quiet performance that isolates road noise and vibration for a quieter ride
- Reliable, greaseable, and rebuildable joints with 40 degrees of misalignment
- Heavy-duty square tubing and DOM housings for maximum strength and durability
- Forged adjusters for precise alignment and adjustability
- Reduced suspension angles for a smoother, more controlled ride
  - Only tested and confirmed use in conjunction with COR-2209100, Front Long Arm Brackets
- Longer arms to deliver greater articulation and climbing ability
- Radius arm hardware (M12 – 1.75 x 80mm bolts, nuts and washers) included
- **Arm dimensions: MIN = 37  $\frac{1}{4}$ " , MAX = 38  $\frac{3}{16}$ " , INSTALL = 37  $\frac{1}{2}$ "**



# REAR SUSPENSION COMPONENTS

\*\*\*Please review the part numbers you have purchased to familiarize yourself with the product(s)\*\*\*



# 5009210 - INCLUDED ITEMS

5009210 Jeep Wrangler REAR Overland+ 3.6 V6 Long Arm Upgrade Kit (2018+, JL)				
QTY	Part Number	Description	Class/Grade	ID Number
1	2209200	Jeep Rear Left/Right Long Arm Frame Brackets	N/A	1
1	1909020	Jeep Overland+ Long Rear Lower Control Arms	N/A	2
1	1909030	Jeep Overland+ Long Rear Upper Control Arms	N/A	3
4	18951	9/16"-18 x 4" Zinc Finish Hex Cap Screw	Grade 8	4
8	33818	9/16" Zinc Finish SAE Thru-Hardened Flat Washer	Thru-Hardened	5
4	37310	9/16"-18 Zinc Finish Top Lock Nut	Grade C	6

## Product Notes and Features:

Achieve superior performance and durability with the **Ultimate Jeep Control Arms**, engineered for unmatched comfort and reliability. Designed with meticulous attention to detail, these control arms are built to handle the toughest terrains while delivering a smooth and quiet driving experience.

- Weld-on frame brackets made of 1/4" thick steel construction
- Utilizes the factory axle mounting points, no axle modification required
- Reduced suspension angles for a smoother, more controlled ride
- Longer arms to deliver greater articulation and climbing ability
  - **Lower arm dimensions: MIN = 35  $\frac{1}{4}$ " , MAX = 37" , INSTALL = 35  $\frac{1}{2}$ "**
  - **Upper arm dimensions: MIN = 31  $\frac{7}{8}$ " , MAX = 33  $\frac{1}{4}$ " , INSTALL = 32  $\frac{7}{16}$ "**
- GIIRO Joint bushings on the axle and adjusters for smoother on-road handling, superior off-road articulation, and long-lasting reliability
- No exhaust modification necessary for 3.6L V6 JL, 2.0L I4, or 392 V8 HEMI



# 4809210 - INCLUDED ITEMS

4809210 Jeep Wrangler REAR Premium 3.6 V6 Long Arm Upgrade Kit (2018+, JL)				
QTY	Part Number	Description	Class/Grade	ID Number
1	2209200	Jeep Rear Left/Right Long Arm Frame Brackets	N/A	1
1	1909220	Jeep Premium Long Rear Lower Control Arms	N/A	2
1	1909230	Jeep Premium Long Rear Upper Control Arms	N/A	3
4	18951	9/16"-18 x 4" Zinc Finish Hex Cap Screw	Grade 8	4
8	33818	9/16" Zinc Finish SAE Thru-Hardened Flat Washer	Thru-Hardened	5
4	37310	9/16"-18 Zinc Finish Top Lock Nut	Grade C	6

## Product Notes and Features:

Achieve superior performance and durability with the **Ultimate Jeep Control Arms**, engineered for unmatched comfort and reliability. Designed with meticulous attention to detail, these control arms are built to handle the toughest terrains while delivering a smooth and quiet driving experience.

- Weld-on frame brackets made of 1/4" thick steel construction
- Utilizes the factory axle mounting points, no axle modification required
- Reduced suspension angles for a smoother, more controlled ride
- Longer arms to deliver greater articulation and climbing ability
  - **Lower arm dimensions: MIN = 35  $\frac{3}{16}$ " , MAX = 36  $\frac{1}{16}$ " , INSTALL = 35  $\frac{1}{2}$ "**
  - **Upper arm dimensions: MIN = 32  $\frac{1}{8}$ " , MAX = 33  $\frac{3}{8}$ " , INSTALL = 32  $\frac{7}{16}$ "**
- GIIRO Joint bushings on the axle end and Johnny Joints at the adjusters for superior off-road articulation, maximum versatility, and long-lasting reliability
- No exhaust modification necessary for 3.6L V6 JL, 2.0L I4, or 392 V8 HEMI



## 2209200 - INCLUDED ITEMS

2209200 Jeep Wrangler REAR Long Arm Frame Brackets (2018+, JL)

QTY	Part Number	Description	Class/Grade	ID Number
1	2209200	Jeep Rear Left/Right Long Arm Frame Brackets	N/A	1
4	18951	9/16"-18 x 4" Zinc Finish Hex Cap Screw	Grade 8	2
8	33818	9/16" Zinc Finish SAE Thru-Hardened Flat Washer	Thru-Hardened	3
4	37310	9/16"-18 Zinc Finish Top Lock Nut	Grade C	4

### Product Notes and Features:

The Jeep Wrangler Rear Long Arm Frame Brackets (2018+, JL) are designed to relocate the control arm mounting points for a long arm kit upgrade. Built tough and engineered for performance, these brackets are essential for achieving the improved geometry and handling that a long arm kit provides.

- Weld-on frame brackets made of ¼" thick steel construction
- formed using the latest CAD software and manufacturing techniques
- Complete hardware kit included (comes with 9/16" bolts, washers, and nuts)
- Cutting and welding required
- Control arms not included

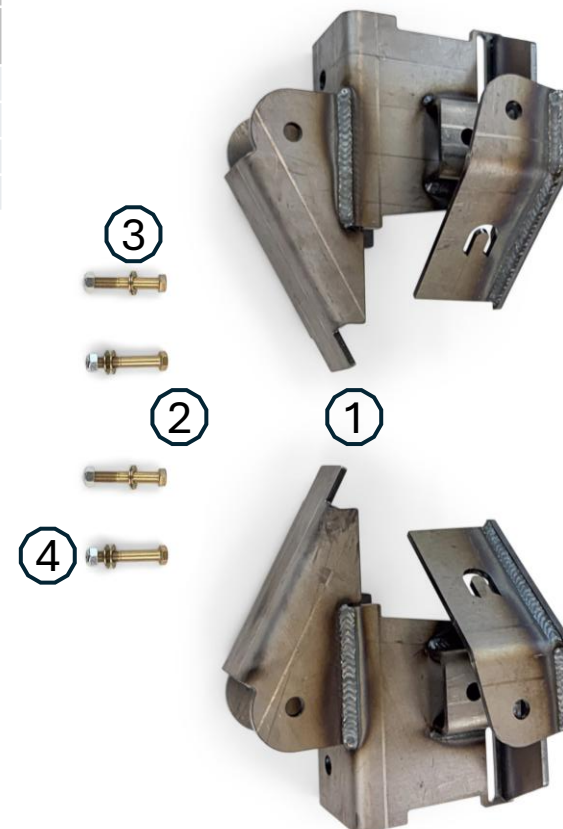

# 1909030 - INCLUDED ITEMS

1909030 Jeep Wrangler Overland+ REAR Upper Control Arms (2018+, JL)				
QTY	Part Number	Description	Class/Grade	ID Number
1	1909030	Jeep Overland+ Long Rear Upper Control Arms	N/A	1

## Product Notes and Features:

Achieve superior performance and durability with the **Ultimate Jeep Control Arms**, engineered for unmatched comfort and reliability. Designed with meticulous attention to detail, these control arms are built to handle the toughest terrains while delivering a smooth and quiet driving experience.

- Maintenance-free, dual-durometer design isolates road noise and vibration for a quieter ride
- Self-centering with 26.6 degrees of total articulation, ensuring smooth suspension movement
- Heavy-duty DOM tubing and housings for maximum strength and durability
- Forged adjusters for precise alignment and adjustability
- Reduced suspension angles for a smoother, more controlled ride
  - Only tested and confirmed use in conjunction with COR-2209200, Rear Long Arm Brackets
- Longer arms to deliver greater articulation and climbing ability
- No hardware included
- **Arm dimensions: MIN =  $31 \frac{7}{8}$ "**, **MAX =  $33 \frac{1}{4}$ "**, **INSTALL =  $32 \frac{7}{16}$ "**



# 1909230 - INCLUDED ITEMS

1909230 Jeep Wrangler Premium REAR Upper Control Arms (2018+, JL)				
QTY	Part Number	Description	Class/Grade	ID Number
1	1909230	Jeep Premium Long Rear Upper Control Arms	N/A	1

## Product Notes and Features:

Achieve superior performance and durability with the **Ultimate Jeep Control Arms**, engineered for unmatched comfort and reliability. Designed with meticulous attention to detail, these control arms are built to handle the toughest terrains while delivering a smooth and quiet driving experience.

- Smooth and quiet performance that isolates road noise and vibration for a quieter ride
- Reliable, greaseable, and rebuildable joints with 40 degrees of misalignment
- Heavy-duty DOM tubing and housings for maximum strength and durability
- Forged adjusters for precise alignment and adjustability
- Reduced suspension angles for a smoother, more controlled ride
  - Only tested and confirmed use in conjunction with COR-2209200, Rear Long Arm Brackets
- Longer arms to deliver greater articulation and climbing ability
- No hardware included
- **Arm dimensions: MIN =  $32 \frac{1}{8}$ "**, **MAX =  $33 \frac{3}{8}$ "**, **INSTALL =  $32 \frac{7}{16}$ "**



# 1909020 - INCLUDED ITEMS

1909020 Jeep Wrangler Overland+ REAR Lower Control Arms (2018+, JL)				
QTY	Part Number	Description	Class/Grade	ID Number
1	1909020	Jeep Overland+ Long Rear Upper Control Arms	N/A	1

## Product Notes and Features:

Achieve superior performance and durability with the **Ultimate Jeep Control Arms**, engineered for unmatched comfort and reliability. Designed with meticulous attention to detail, these control arms are built to handle the toughest terrains while delivering a smooth and quiet driving experience.

- Maintenance-free, dual-durometer design isolates road noise and vibration for a quieter ride
- Self-centering with 26.6 degrees of total articulation, ensuring smooth suspension movement
- Heavy-duty square tubing and DOM housings for maximum strength and durability
- Forged adjusters for precise alignment and adjustability
- Reduced suspension angles for a smoother, more controlled ride
  - Only tested and confirmed use in conjunction with COR-2209200, Rear Long Arm Brackets
- Longer arms to deliver greater articulation and climbing ability
- No hardware included
- **Arm dimensions: MIN =  $35 \frac{1}{4}$ " , MAX = 37" , INSTALL =  $35 \frac{1}{2}$ "**



# 1909220 - INCLUDED ITEMS

1909220 Jeep Wrangler Premium REAR Lower Control Arms (2018+, JL)				
QTY	Part Number	Description	Class/Grade	ID Number
1	1909020	Jeep Premium Long Rear Upper Control Arms	N/A	1

## Product Notes and Features:

Achieve superior performance and durability with the **Ultimate Jeep Control Arms**, engineered for unmatched comfort and reliability. Designed with meticulous attention to detail, these control arms are built to handle the toughest terrains while delivering a smooth and quiet driving experience.

- Smooth and quiet performance that isolates road noise and vibration for a quieter ride
- Reliable, greaseable, and rebuildable joints with 40 degrees of misalignment
- Heavy-duty square tubing and DOM housings for maximum strength and durability
- Forged adjusters for precise alignment and adjustability
- Reduced suspension angles for a smoother, more controlled ride
  - Only tested and confirmed use in conjunction with COR-2209200, Rear Long Arm Brackets
- Longer arms to deliver greater articulation and climbing ability
- No hardware included
- **Arm dimensions: MIN =  $35 \frac{3}{16}$ "**, **MAX =  $36 \frac{1}{16}$ "**, **INSTALL =  $35 \frac{1}{2}$ "**



# INSTALLATION INSTRUCTIONS

**\*\*\*Take this product to a licensed professional if you are hesitant about the installation process!\*\*\***

**The following instructions are applicable to the listed components below:**

- 5009201 / 4809201
- 5009301 / 4809301
- 2209100 / 2209110
- 1709101 / 1809101
- 1909010 / 1909210

**The following instructions provide a complete guide for installing a full front upgrade kit, compatible with 2018+ 3.6L V6 JL/JT, and the 2021+ 392 V8 HEMI JL**

**\*\*\*2.0L I4 JL owners may follow these instructions as a general guide, however additional steps may apply\*\*\***

**\*\*\*The following steps apply to both 3.6 V6 and 392 V8 HEMI JL vehicles, unless noted otherwise\*\*\***

**If you purchased single arm sets, individual brackets, or an incomplete kit, your installation process may vary.**

We strongly recommend having basic mechanic's hand tools, sockets, wrenches, vehicle jacks and stands, and other common tools readily available. Installing an aftermarket lift kit is a detailed process, and having the right tools on hand will ensure a smoother installation.

**As always, feel free to contact us at any point during your installation - you can count on us to help!**

# INSTALLATION INSTRUCTIONS

## TOOLS REQUIRED FOR INSTALLATION

- *Basic hand tools*
- *Metric wrench/socket set* (10mm - 24mm)
- *Standard wrench/socket set* (7/16", 1/2", 15/16")
- *MIG welder*
- *Cut-off wheel or plasma cutter*
- *Large box wrenches* (1-1/2", 1-7/8")
- *Jack stands and/or vehicle lift*

1. Position the vehicle either on the ground or on a lift. For this installation, it is recommended that the vehicle be supported by the frame. Support the front axle with an additional jack stand. Remove the front tires and disconnect the battery before welding.

**\*\*\*Photos of control arm adjusters in the following photos may not match your selected series, but the installation remains the same!\*\*\***



Figure 1: Vehicle on four-post lift

# INSTALLATION INSTRUCTIONS

2. If adjustable control arms are currently installed, loosen the jam nuts while the arms are still installed. Before installing the control arm brackets, please make sure the following pre-installation checklist is completed.

## PRE-INSTALLATION CHECKLIST

- Remove the plastic fuel-line shield on the passenger side (Figure 2)
- Cut off the stud on the frame for the gas tank shield (Figure 2)
- Remove the cross-member bolts and swap them around **\*3.6 V6 ONLY\*** (Figure 3)
- Remove the exhaust section at the flange near the front, and the coupling before the resonator in the rear **\*3.6 V6 ONLY\*** (Figure 4)
- Remove the transmission guard

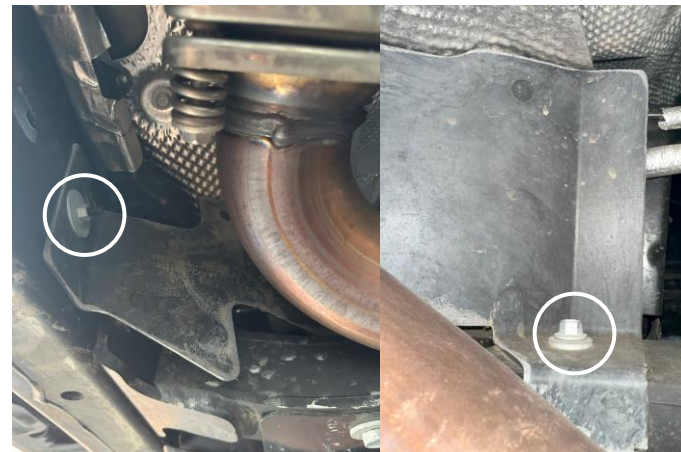

Figure 2: Fuel-line shield bolts (passenger side)



Figure 4: Exhaust section flanges and clamps



Figure 3: Cross-member bolts flipped around

# INSTALLATION INSTRUCTIONS

2b. **392 V8 HEMI NOTE:** Removing the cross-member entirely will greatly assist in the removal of the exhaust. This requires the use of an additional jack stand to support the transmission. Please follow the steps below to remove the cross member before attempting to remove the exhaust.

## CROSS-MEMBER REMOVAL CHECKLIST - V8 HEMI ONLY

- Unbolt the x3 nuts holding the transmission to the cross member (Figure 4a)
- Support the transmission with an adjustable locking jack stand
- Unbolt the x3 thru-bolts at the frame rail (Figure 4b)
- Unbolt the x2 exhaust hanger bolts that are mounted to the cross member (Figure 4c)
- Unbolt the x2 thru-bolts on the other side of the cross member (Figure 4d)



Figure 4a: Transmission nuts



Figure 4b: Frame rail thru-bolts



Figure 4d: Cross-member bolts



Figure 4c: Cross-member exhaust hanger

# INSTALLATION INSTRUCTIONS

2c. **392 V8 HEMI NOTE:** With the cross-member removed and the transmission supported, remove the exhaust.

Removing the exhaust is crucial for this installation, but modification is **not** required! This will open-up the work area and allow for smoother removal factory control arm brackets, as well as make room for the new, weld-on brackets. The exhaust must be removed all the way from the front pipes to the muffler. Please follow the checklist below to remove the exhaust.

## EXHAUST REMOVAL CHECKLIST - 392 V8 HEMI ONLY

- Unbolt the passenger and driver front pipe/converter (Figure 4e)
- Unbolt the passenger side cross-over pipe at the flange (Figure 4f)
- Unbolt the rear section pipe clamp bolts at the resonator (Figure 4g)
- Remove the rear section muffler clamps (Figure 4h)
- Disconnect the O<sub>2</sub> sensors before removal!**

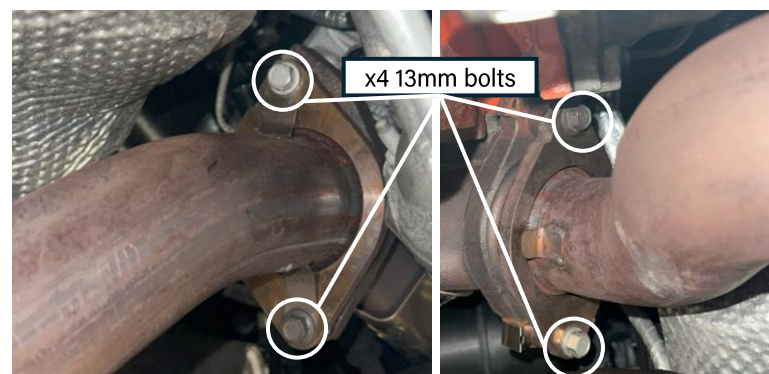

Figure 4e: Front pipe flange (driver/passenger side)

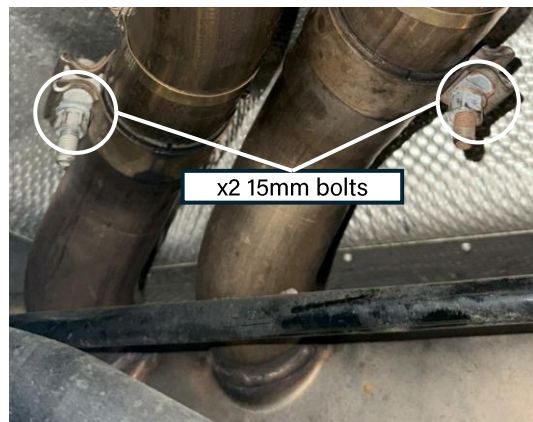

Figure 4h: Rear section muffler clamps

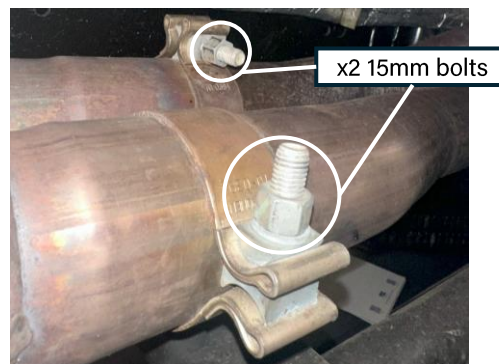

Figure 4g: Rear section resonator clamps

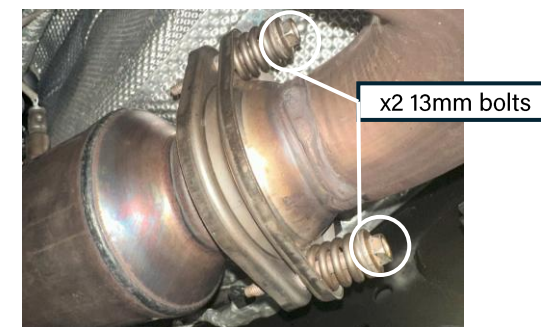

Figure 4f: Spring bolts at cross-over pipe (passenger side)

# INSTALLATION INSTRUCTIONS

2d. **392 V8 HEMI NOTE:** With hangers and the exhaust clamps loosened and/or removed, you may now remove the exhaust sections piece by piece. Remove the two rear exhaust section hangers and then remove the front pipe sections (passenger and driver) followed by the cross-over pipe section.

Move to the rear and remove the resonator section. Slowly wiggle the section back and forth in circular motions until the angled pipes back out of the muffler. See the figures below for the hangers (Figure 4j) and the entire exhaust system out of the vehicle (Figure 4k).

**Be sure not to damage the O<sub>2</sub> sensors while removing exhaust sections!**

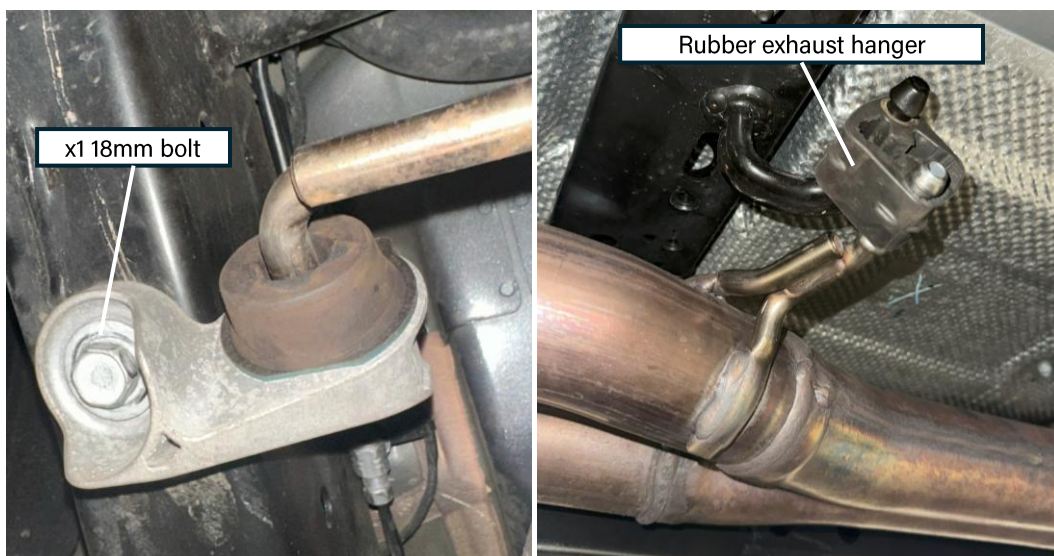

Figure 4j: Remaining exhaust hangers to be removed

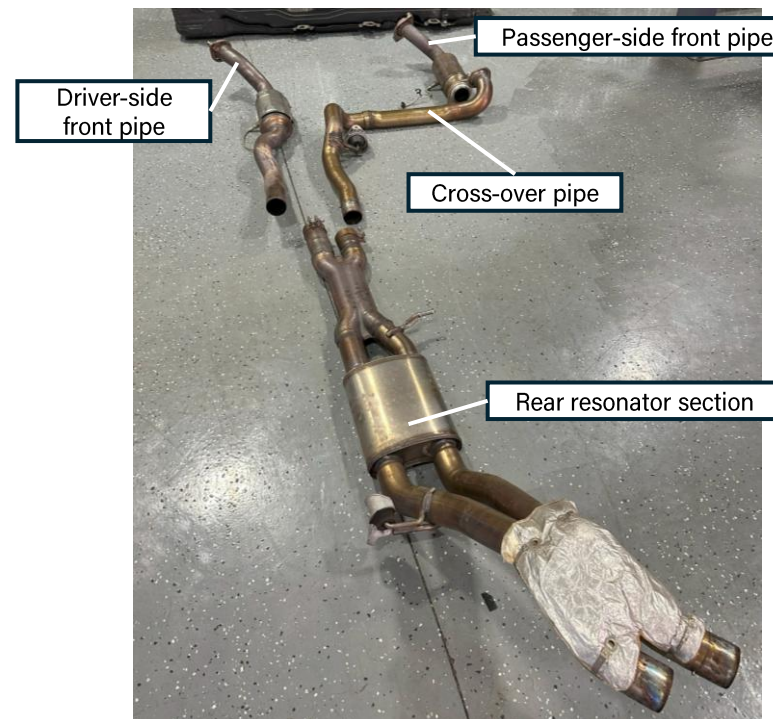

Figure 4k: Full exhaust system removed

# INSTALLATION INSTRUCTIONS

3. Remove both front lower control arms and begin cutting off the lower control arm brackets from the frame. It is recommended to cut the bracket just below the weld and then grind the weld flat. Complete this step for both sides. See Figure 5 for the front lower control arm bracket on the passenger side of the vehicle (highlighted in blue).

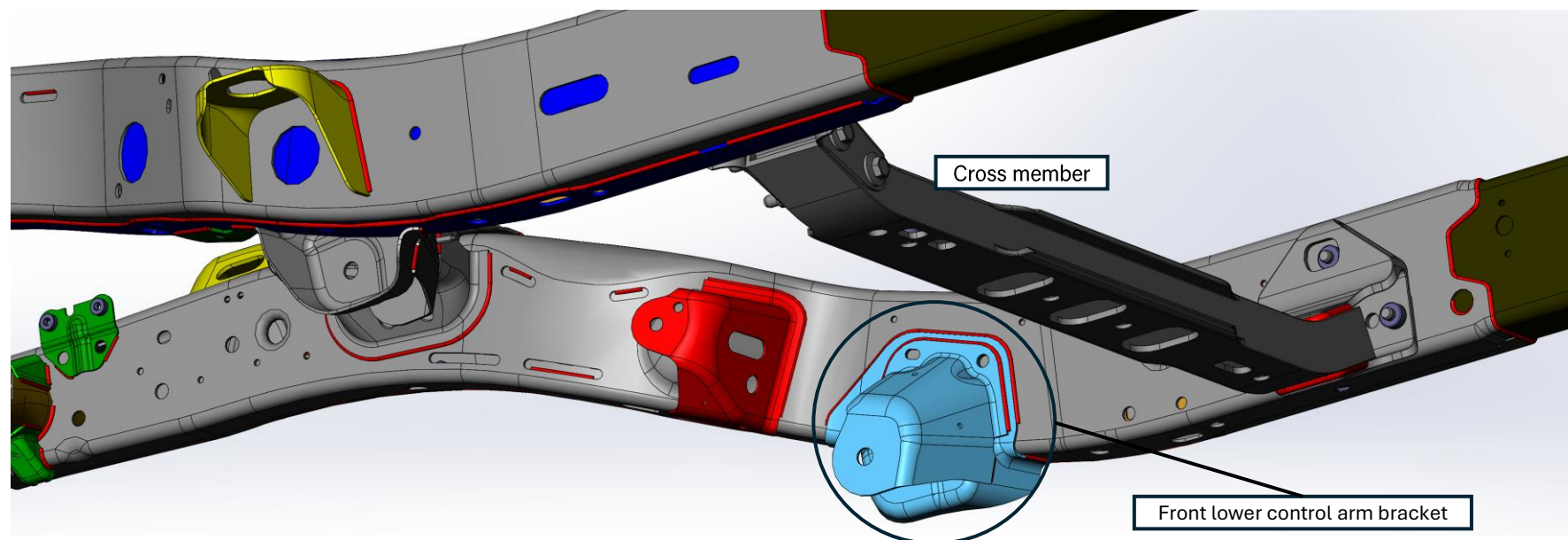

Figure 5: CAD model of original front upper and lower control arm bracket locations

# INSTALLATION INSTRUCTIONS

4. Removal of the front upper control arm brackets might not be necessary depending on various suspension setup factors such as lift height, bump stops, and shocks. For a clean and finished look, remove the bracket as it won't be reused.

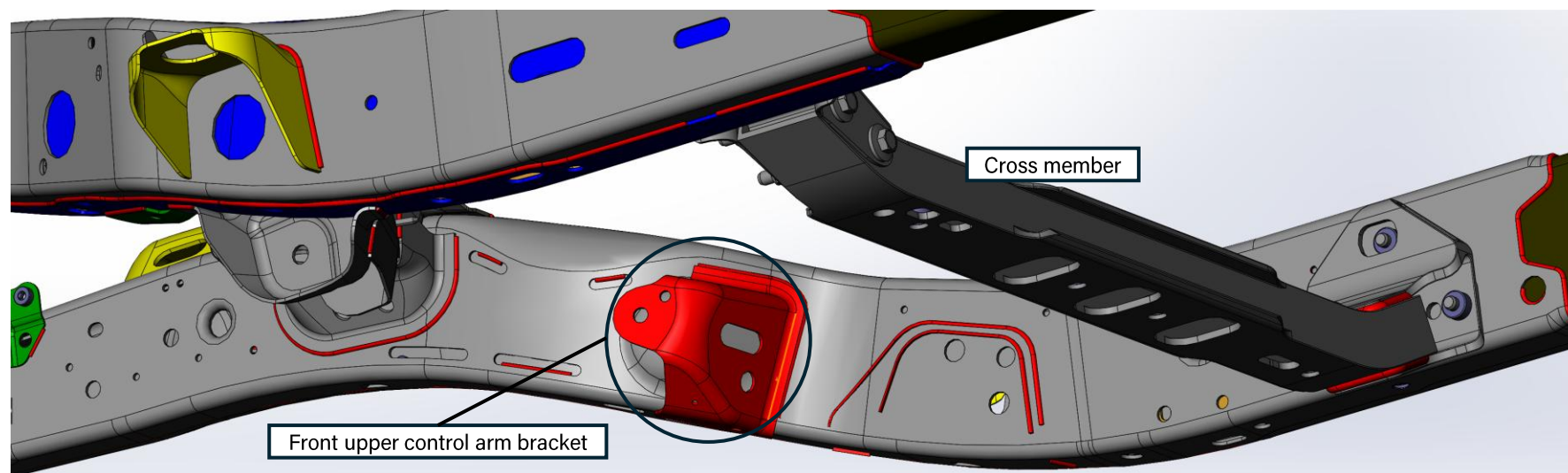

Figure 6: CAD model of original front upper control arm bracket location (front lower bracket already removed)

**NOTE:** At full flex, the upper radius arm on aggressive suspension setups (taller lifts with longer travel) may rub against this bracket, so removing it is the worry-free option.

# INSTALLATION INSTRUCTIONS

5. Once the control arm brackets are cut off and the welds are ground flat, prepare the area for welding. Remove any paint and clean the bare metal surface.

Position the lower control arm brackets on the frame rail. Using the slotted hole on the frame, **measure back 3/16"** and slide the bracket over the rail at this location. **Mark this location with a sharp tool. Make sure that the cross member bolt head is on the opposite side of the cross member (Cross-member is removed for 392 V8 installation).**

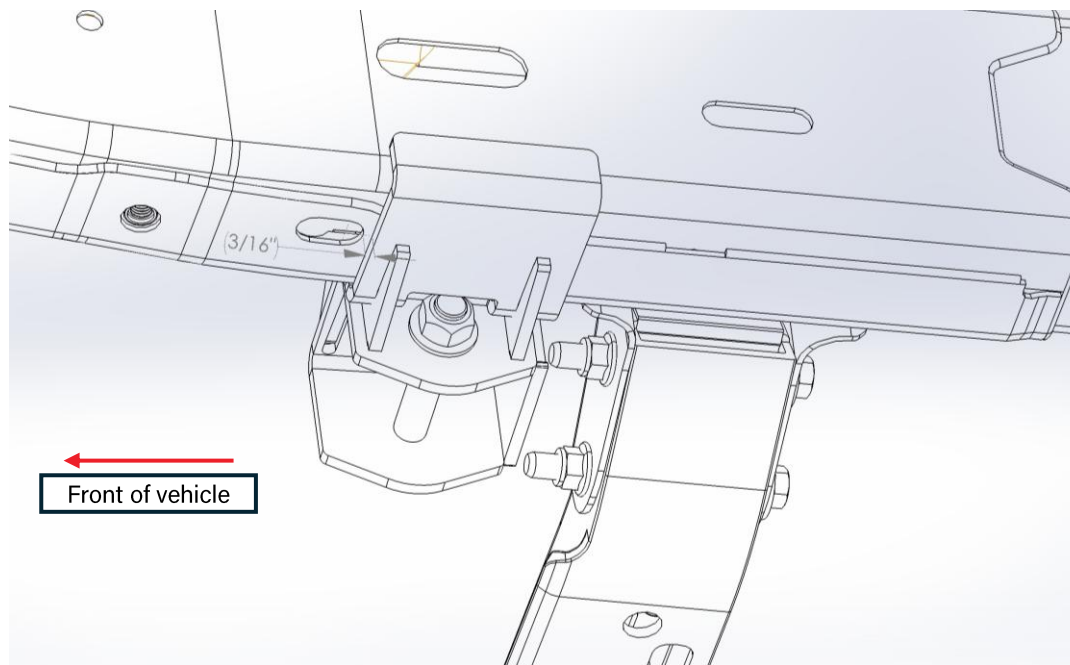

Figure 7: CAD model of bracket installed over frame rail (driver side)

# INSTALLATION INSTRUCTIONS

6. Secure the brackets so that they sit flush on the frame rail by using a mallet or dead-blow hammer. Before welding, confirm that the bracket sits  $3/16$ " behind the slot in the frame.

Weld completely around the entire outside edge of the frame rail bracket. Be mindful of the coolant and brake lines when welding on the brackets. Unclip and move them out of the way or shield them using a piece of scrap metal.



Figure 8: Bracket welded along edge to frame rail and area painted black

**392 V8 HEMI NOTE:** Hardware should be installed with the bolt head facing out (as pictured above), otherwise, the bolt will not be able to be removed due to the exhaust resonator being in the way.

# INSTALLATION INSTRUCTIONS

7. Install one lower control arm. The lower arms set the wheelbase of the axle. Set their length to the install length found at the beginning of this document. Ensure they are both the **same length**. Put the arms side by side and run a bolt through both ends to ensure they are equal in length.

Reuse the original hardware from the previous lower control arms on the axle. Use the supplied 5/8"-18 x 4" bolts along with washers and top lock nuts for the frame bolts.

Next, loosely install the short upper control arm using the supplied M12-1.75 x 80mm bolt, washers, and hardware at the radius linkage "C" mount. Set their length to the install length found at the beginning of this document. Reuse the original hardware for the upper control arm mount to the axle.

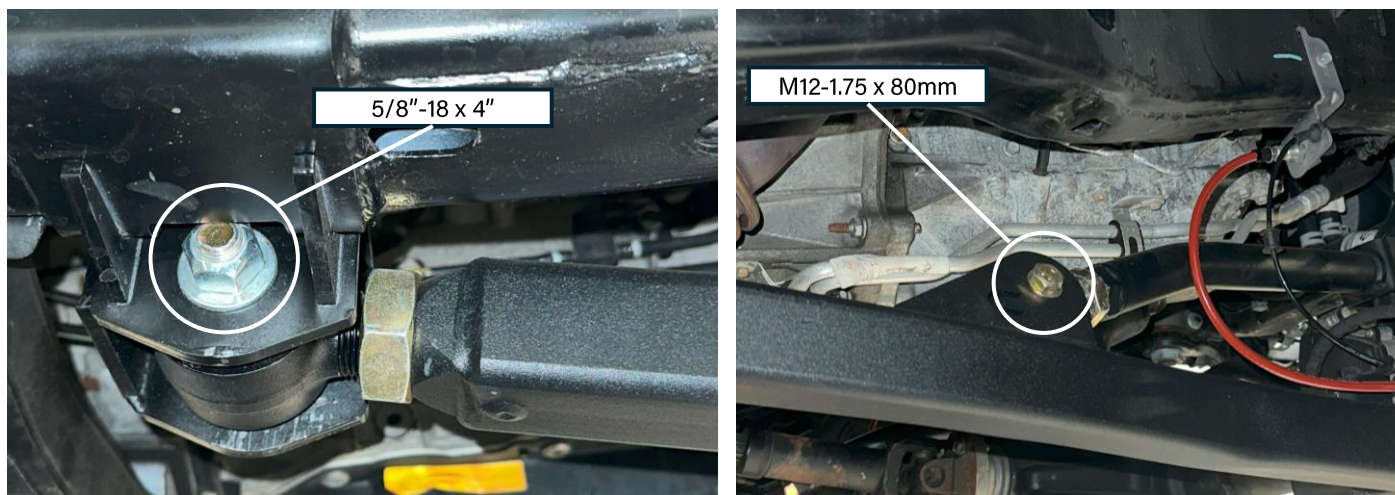

Figure 9: Frame bracket with lower arm (adjuster end) installed using supplied hardware

**NOTE:** Make sure that both upper and lower arm adjusters are positioned on the frame side, and that the upper arm mount is angled inward.

# INSTALLATION INSTRUCTIONS

8. Install the other lower control arm (same length as the first side) using supplied and original hardware. **Leave this side's upper control arm out for now.** Visually check the wheelbase positioning by comparing the axle and frame coil buckets and shock positioning. Adjust the wheelbase length as needed by threading in/out **both lower control arm adjusters equally.**

Next, set the vehicle at ride height. Reinstall this side's tire and use a jack stand to support the other end. To set the pinion and caster angle:

- Support the pinion with a car jack
- Remove the upper control arm bolt at the "C" mount
- Use the jack to set the desired caster and pinion angle (use a digital angle finder). We recommend 5.5°-6°
- Lengthen or shorten the upper control arm adjuster to achieve the desired angle and tighten
- Installing the other upper control arm on the other side to fit, without touching the jack. **The upper control arms do not need to be the same length and can vary slightly!**



Figure 10: Passenger side lower and upper control arms installed

# INSTALLATION INSTRUCTIONS

9. Torque all hardware. Refer to the table below for helpful torque specifications. It is recommended to retorque all bolts after the first 500 miles of driving.

Table 1: COR FRONT Long Arm Torque Specifications

Bolt Location	Wrench Size	Torque (ft-lbs)
Upper Control Arm Radius Link Bolt (M12-1.75 x 80mm)	19mm	100
Upper Control Arm Axle Bolt (Factory Size)	18mm	80
Lower Control Arm Frame Bolt (5/8"-18 x 4")	15/16"	180
Lower Control Arm Axle Bolt (Factory Size)	21 and 24mm	180

# INSTALLATION INSTRUCTIONS

10. Tighten down the jam nuts on the upper and lower control arms. Use a 1-7/8" wrench for the lower control arm jam nuts, and a 1-1/2" wrench for the upper control arm jam nuts. Use a breaker bar to gain additional leverage. Tighten all jam nuts down as tight as humanly possible.

Please note that not all wrenches are created with the same tolerances. If your wrenches are too loose around the jam nut, Clayton Off Road offers tight, wrap-around wrenches for purchase. Please search for the wrenches using the SKUs below.



Figure 11: COR Wrench-ends for control arm jam nuts (COR-2500125, COR-2500100)

# INSTALLATION INSTRUCTIONS

11. Once the frame and brackets are painted, reinstall the exhaust and cross-member (if it was removed). Please follow the post-installation checklist to complete the installation. As always, feel free to contact us with any questions you may have about the installation.



## POST-INSTALLATION CHECKLIST:

- Frame brackets are properly welded entirely to the frame
- The work area is fully painted
- Exhaust is reinstalled completely (Leave out if installing rear upgrade kit)
- Coolant/brake lines are put back into place and are not damaged
- All hardware is torqued to specification (see Step 9)
- Control arm jam nuts are as tight as possible
- Lug nuts are torqued to the manufacturer's specification
- A licensed shop has professionally aligned the vehicle
- Retorque all hardware after 500 miles of driving



# INSTALLATION INSTRUCTIONS

**\*\*\*Take this product to a licensed professional if you are hesitant about the installation process!\*\*\***

**The following instructions are applicable to the listed components below:**

- 5009210 / 4809210
- 2209200
- 1909030 / 1809230
- 1909020 / 1909220

**The following instructions provide a complete guide for installing a full rear upgrade kit, compatible with 2018+ 3.6L V6 JL/JT, and the 2021+ 392 V8 HEMI JL.**

**\*\*\*2.0L I4 JL owners may follow these instructions as a general guide, however additional steps may apply\*\*\***

**\*\*\*The following steps apply to both 3.6 V6 and 392 V8 HEMI JL vehicles, unless noted otherwise\*\*\***

**If you purchased single arm sets, individual brackets, or an incomplete kit, your installation process may vary.**

We strongly recommend having basic mechanic's hand tools, sockets, wrenches, vehicle jacks and stands, and other common tools readily available. Installing an aftermarket lift kit is a detailed process, and having the right tools on hand will ensure a smoother installation.

**As always, feel free to contact us at any point during your installation - you can count on us to help!**

# INSTALLATION INSTRUCTIONS

## TOOLS REQUIRED FOR INSTALLATION

- *Basic hand tools*
- *Metric wrench/socket set* (10mm - 24mm)
- *Standard wrench/socket set* (13/16", 7/8")
- *Large box wrenches* (1 - 1/2", 1 - 7/8")
- *Jack stands and/or vehicle lift*
- *MIG welder*
- *Cut-off wheel or plasma cutter*

12. Position the vehicle either on the ground or on a lift. For this installation, it is recommended that the vehicle be supported by the frame. Support the rear axle with an additional jack stand. Remove the rear tires and disconnect the battery before welding.

**\*\*\*Photos of control arm adjusters in the following photos may not match your selected series, but the installation remains the same!\*\*\***



Figure 12: Installation photo

# INSTALLATION INSTRUCTIONS

13. Follow the pre-installation checklist below to ensure a smooth installation process. These steps are designed to simplify the later stages of the installation and create proper clearance for welding the frame brackets during the long-arm upgrade.

## PRE-INSTALLATION CHECKLIST

- Remove the plastic fuel-line shield on the passenger side (Figure 13). If you have already installed the Front Long Arm Upgrade Kit, this shield will not be present. It will not be reused once the upgrade kit is installed
- Remove the rear exhaust section at the clamps near the muffler and the cross member (Figure 14) and fully remove the section **\*3.6 V6 JL ONLY\***. If installing the rear upgrade kit on a 392 V8 HEMI JL, the entire exhaust section must be removed



Figure 13: Fuel-line shield bolts (passenger side)

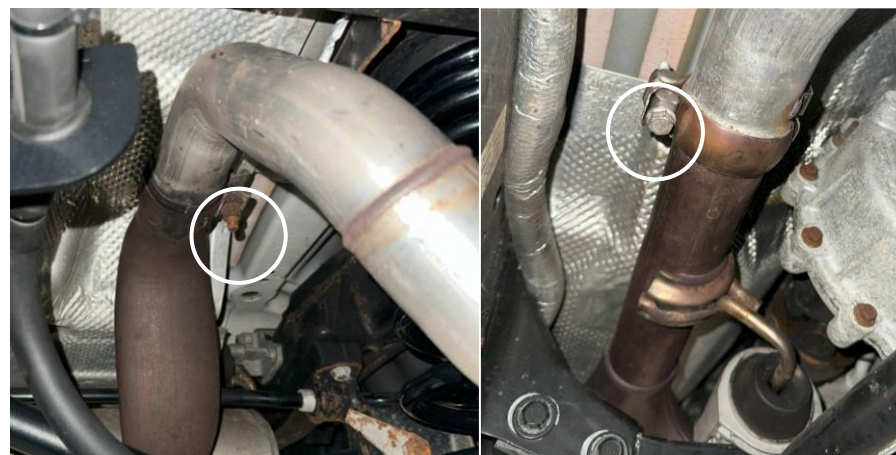

Figure 14: Rear exhaust section clamps to be removed (3.6 V6 JL)

# INSTALLATION INSTRUCTIONS

14. If adjustable control arms are currently installed, loosen the jam nuts while the arms are still installed. The gas tank will need to be removed to install the driver's side control arm bracket. We recommend draining the gas tank to less than  $\frac{1}{4}$  empty before removing it. **Support the gas tank with two additional jack stands** before continuing in this installation.

## GAS TANK REMOVAL

- ❑ Remove the transfer case skid plate using the socket sizes noted if it is not removed already (Figure 15)
- ❑ Remove the (6) bolts holding the gas tank in place and **slowly lower the tank 3-4 inches using the supporting jack stands**. You'll find 3 bolts on the frame rail, 1 on the front cross member, and 2 on the side closest to the driveshaft (Figure 16)

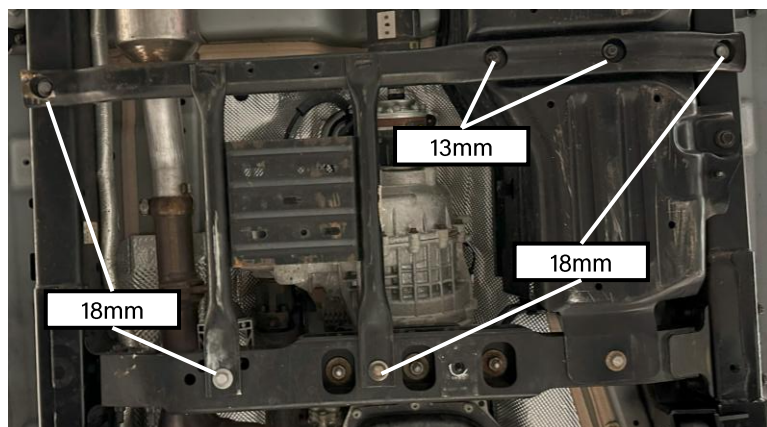

Figure 15: Transfer case skid plate bolts to remove

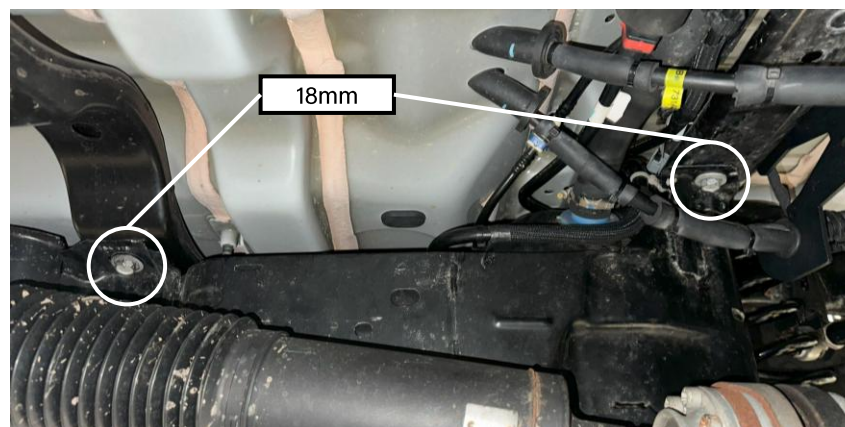

Figure 16: (2 of 6) gas tank bolts

# INSTALLATION INSTRUCTIONS

15. With the gas tank bolts removed, support the tank and lower it by 3-4 inches. The following checklist needs to be completed to fully drop the tank out from under the vehicle. The tank has many lines that all need to be disconnected before the tank is fully dropped. **Take care in disconnecting these lines at the clips, because they are very fragile. KEEP ALL CLIPS.**

## GAS TANK REMOVAL - REAR FUEL CONNECTIONS

- ❑ Loosen the filler neck clamp and slip it off the tube (Figure 17) using a 7mm socket or wrench
- ❑ Remove the filler breather by removing the blue, plastic retaining clip and gently pushing down on the spring clip on the opposite side (Figure 18)
- ❑ Remove the vapor system hose clip by removing the red, plastic retaining clip and gently pushing down on the spring clip on the opposite side (Figure 19)

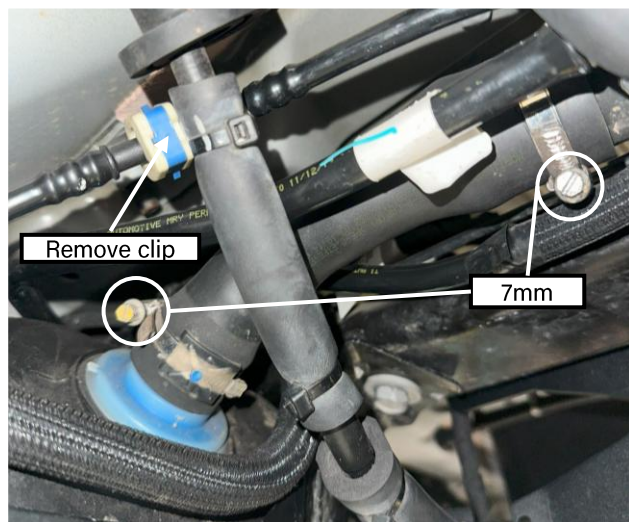

Figure 17: Gas filler neck to be loosened

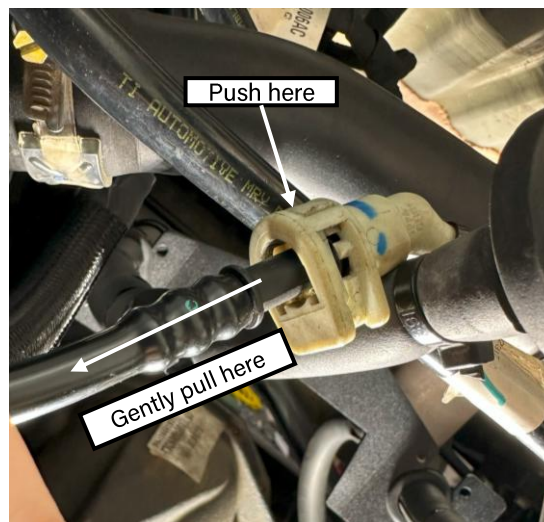

Figure 18: Filler breather clip disconnect

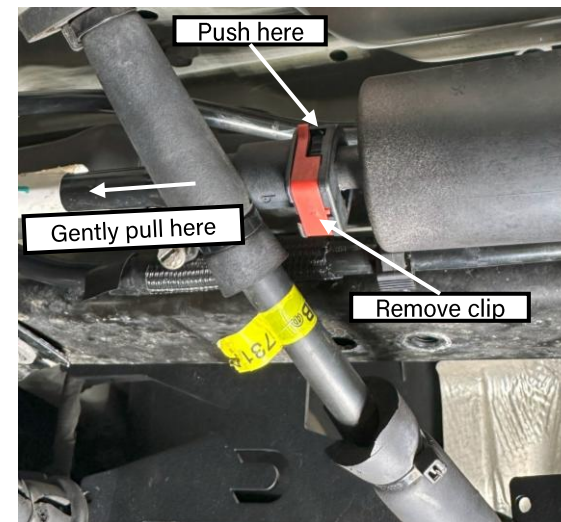

Figure 19: Vapor system hose clip

# INSTALLATION INSTRUCTIONS

16. With the rear fuel lines disconnected, look at the top of the tank. The following list will outline what additional lines/cables need to be removed to safely drop the fuel tank out from under the vehicle. **KEEP ALL CLIPS.**

## GAS TANK REMOVAL - TOP TANK CONNECTIONS

- ❑ Remove the evap canister hose by removing the green plastic clip, pressing in on the back of the spring clip, and gently pulling the line out (same as rear fuel connection clips) as seen in Figure 20
- ❑ Remove the electronic wiring harness located directly behind the evap canister hose clip. This may require the tank to be lowered further to gain additional clearance. **Be mindful of any existing hose retaining clips, remove them with a trim tool**

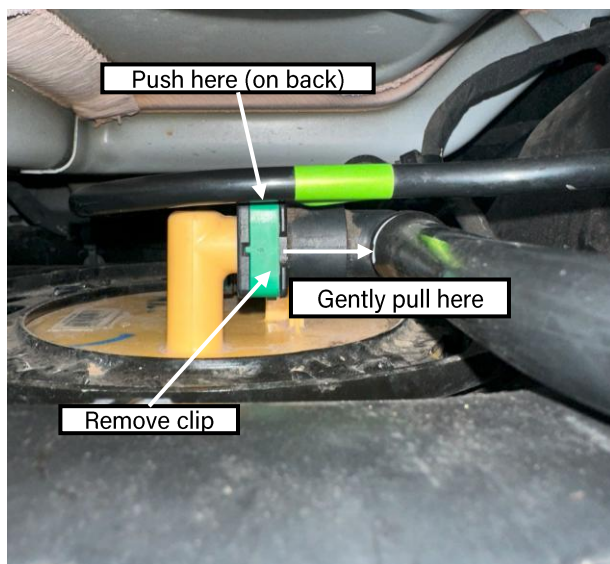

Figure 20: Evap canister hose clip

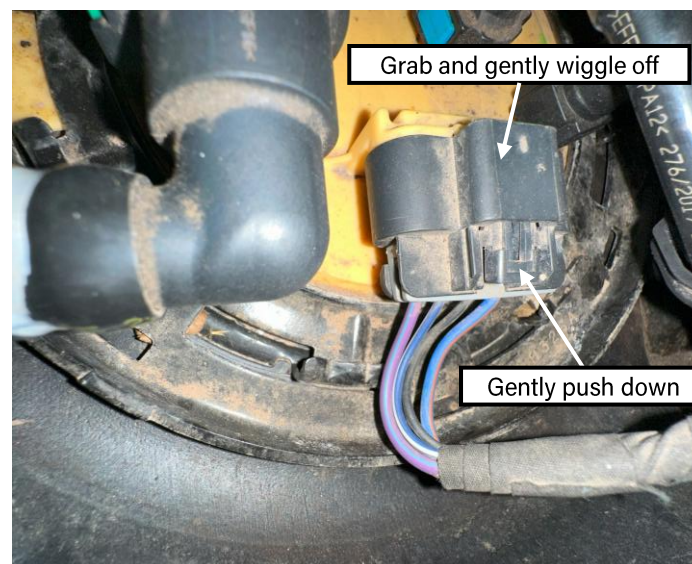

Figure 21: Tank wiring harness to be disconnected

# INSTALLATION INSTRUCTIONS

17. With the rear and top fuel lines/cables disconnected, move to the front of the gas tank to complete the following steps. These lines may be under pressure and still contain fuel. We recommend using a rag to soak up any fuel that's leaking from these lines, or a cup to contain any mess.

## GAS TANK REMOVAL - FRONT TANK CONNECTIONS

- ❑ Remove the two plastic red retaining clips from both lines pictured below (Figure 22)
- ❑ Push down on the opposite sides and pull the line out, gently (same process as previous clip removal)

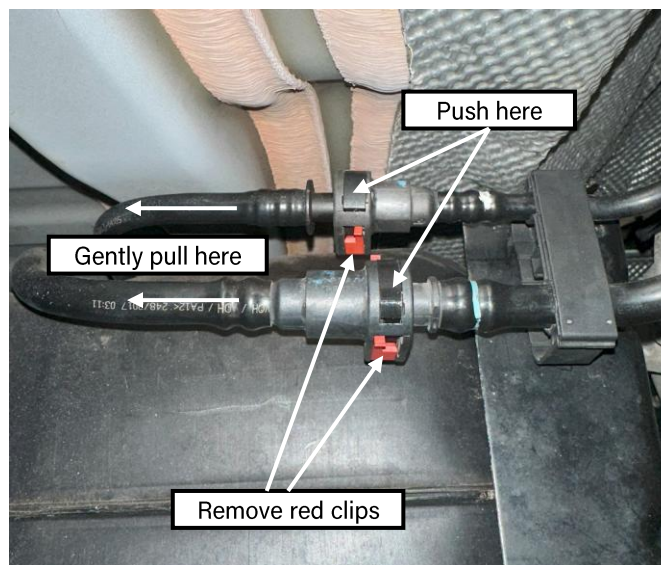

Figure 22: Front of tank connections

**\*\*\*PUT ASIDE ALL PLASTIC RETAINING CLIPS, AS THEY WILL BE REUSED\*\*\***

# INSTALLATION INSTRUCTIONS

18. Before fully dropping the tank, make sure that the tank is completely free of any remaining connections. Slowly drop the tank to gain visible clearance and ensure no hoses, plastic clips, or wires in the way. When the tank is fully dropped, please move it far away from the vehicle, as the installer will be grinding/welding.

## GAS TANK REMOVAL - COMPLETE

- Move the tank far away from the vehicle (at least 20 feet)
- Put something over the front fuel connections and the filler tube to prevent leaks/fumes



Figure 23: Front, top and rear fuel tank connections

**\*\*\*PUT ASIDE ALL PLASTIC RETAINING CLIPS, AS THEY WILL BE REUSED\*\*\***

# INSTALLATION INSTRUCTIONS

19. Remove both rear lower control arms and begin cutting off the lower control arm brackets from the frame. It is recommended to cut the bracket just below the weld and then grind the weld flat. Complete this set for both sides. See Figure 24 for the rear lower control arm bracket on the passenger side of the vehicle (highlighted in red).

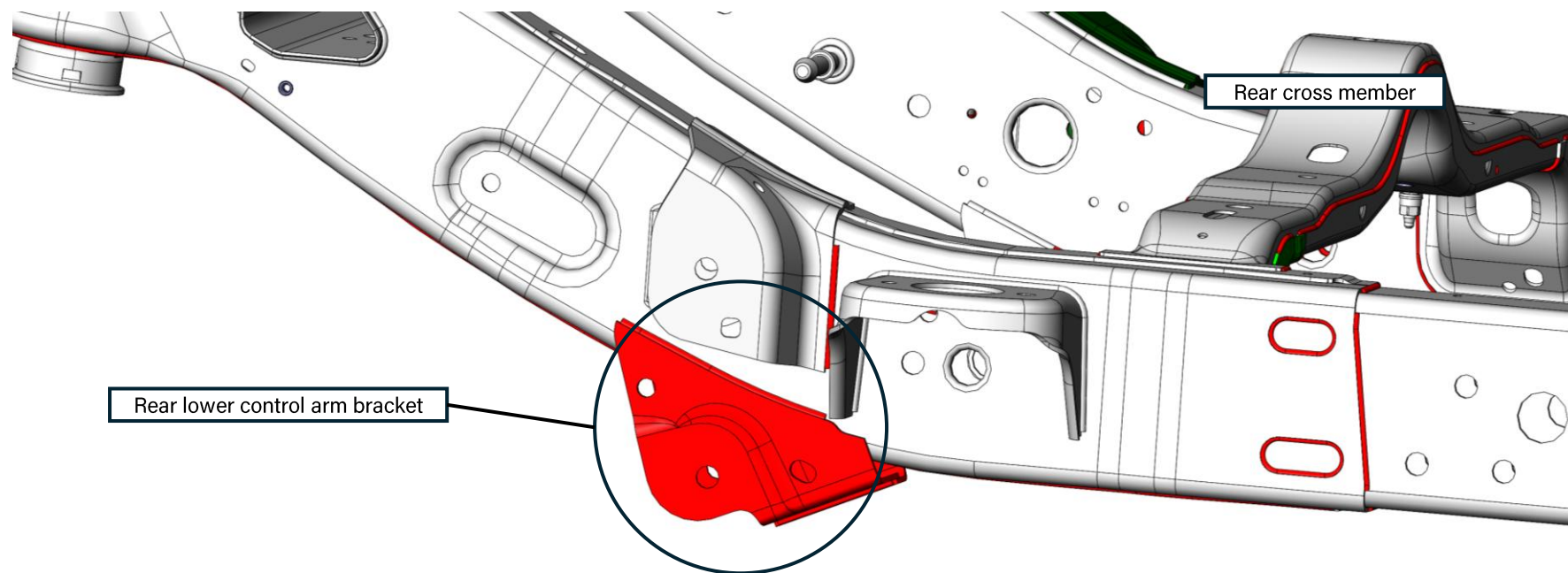

Figure 24: CAD model of original rear lower control arm bracket (passenger side)

# INSTALLATION INSTRUCTIONS

20. Remove both rear upper control arms and begin cutting off the upper control arm brackets from the frame. It is recommended to cut the bracket just below the weld and then grind the weld flat. Using a plasma torch may be easiest. Complete this step for both sides. See Figure 25 for the rear upper control arm bracket on the passenger side of the vehicle (highlighted in blue).

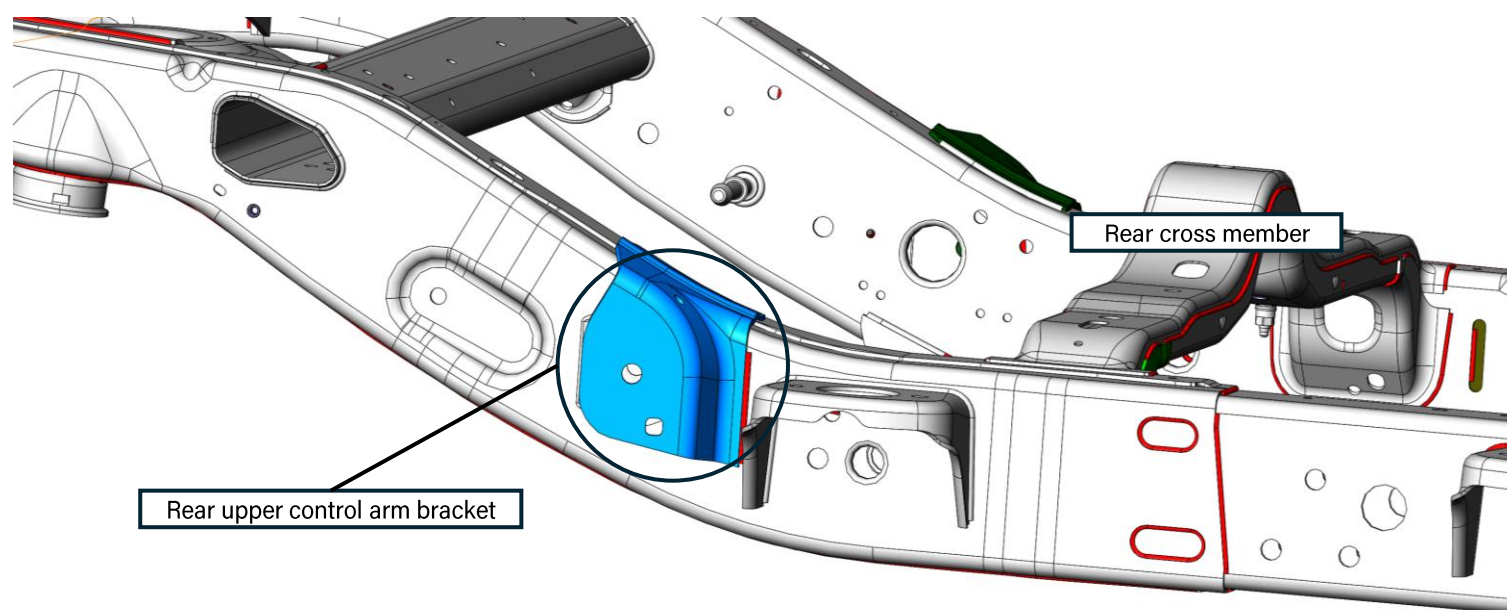

Figure 25: CAD model of original rear upper control arm bracket location (rear lower bracket already removed)

# INSTALLATION INSTRUCTIONS

21. After cutting off the control arm brackets and grinding the welds flat, prepare the area for welding by removing any paint and thoroughly cleaning the bare metal surface.

Position the new control arm brackets on the frame rail, ensuring they align with the sheet metal step on the frame. Verify that the gas tank bolt hole is perfectly concentric with the corresponding hole in the new bracket.

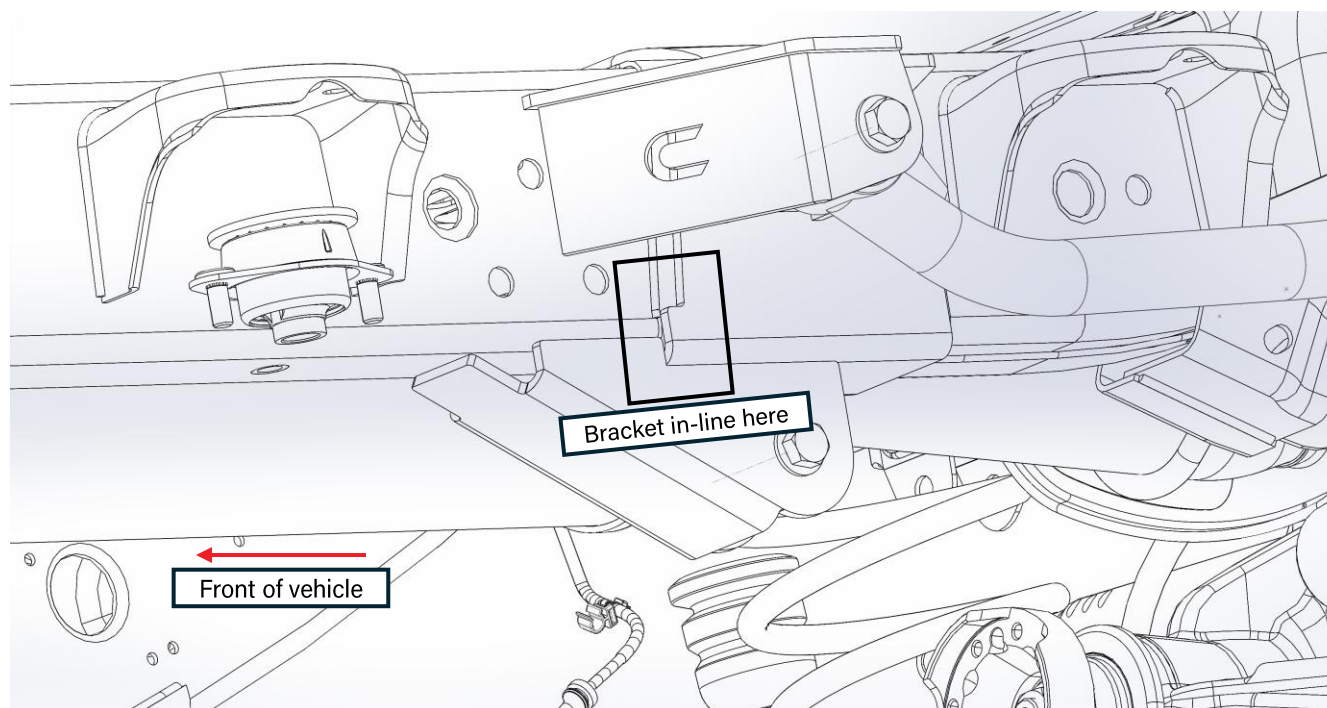

Figure 26: CAD model of bracket installed over frame rail (driver side)

# INSTALLATION INSTRUCTIONS

22. Secure the brackets to sit flush on the frame rail using a mallet or dead-blow hammer. You may also temporarily install one of the gas tank bolts to hold the bracket in place for welding.

Weld completely around the entire outside edge of the frame rail bracket. Be mindful of the coolant and brake lines when welding on the brackets. Unclip and move them out of the way or shield them using a piece of scrap metal. Weld inside and outside of the frame rail.



Figure 27: Bracket welded along the contact edge points to frame rail

# INSTALLATION INSTRUCTIONS

23. Install the lower control arm on the **passenger side**. The lower arms set the wheelbase of the axle. Set their length to the install length found at the beginning of this document. Ensure they are both the **same length**. Put the arms side by side and run a bolt through both ends to ensure they are equal in length. This starting length will get your wheelbase close, but cycling the suspension and checking your axle range will be needed to dial in the rear axle position.

Reuse the original hardware from the previous lower control arms on the axle. Use the supplied 9/16"-18 x 4" bolt along with washers and top lock nut for the frame bolt.

Next, loosely install the upper control arm using the supplied 9/16"-18 x 4" bolt, washers, and top lock nut at the frame bracket. Set their length to the install length found at the beginning of this document. Reuse the original hardware for the upper control arm mount to the axle.

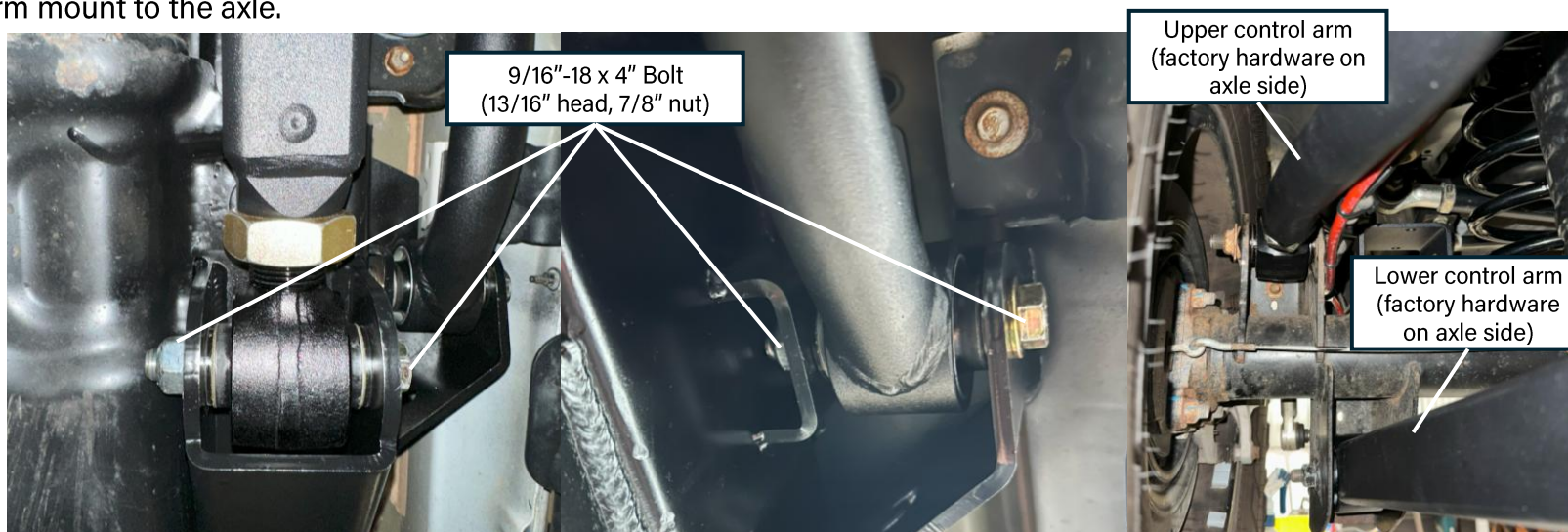

Figure 28: Frame bracket with lower and upper arm (adjuster end) installed using supplied hardware

**NOTE:** Make sure that the adjuster of the lower arm is on the frame side, and the upper arm's adjuster is located on the axle side.

# INSTALLATION INSTRUCTIONS

24. To accommodate the new frame brackets on the gas tank side, one of the gas tank mounts must be trimmed. Please see Figure 29 for a template on where to cut the rear-most frame rail mount on the tank. Use a cut-off wheel to make the cut. **REMOVE THE GAS TANK OUT OF THE SKID BEFORE CUTTING. Cut  $\frac{1}{4}$ " deep, and  $8\text{-}\frac{3}{4}$ " from the hole center.**

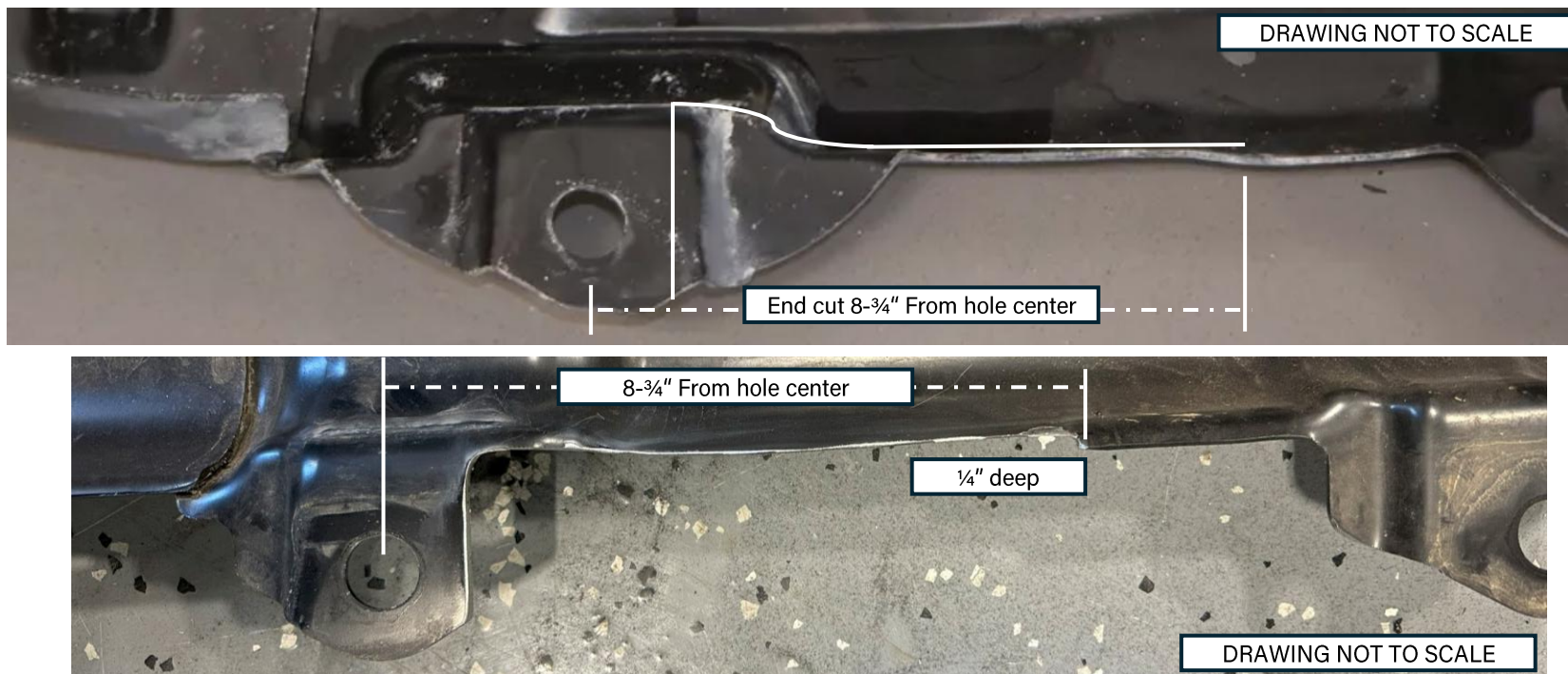

Figure 29: Rear-most gas tank skid plate mount before and after clearance cut

**NOTE:** Trim/notch at the mount, then continue the cut on the edge (white line) of the tank skid until you reach  $8\text{-}\frac{3}{4}$ ". Stop the cut, sand the edge smooth, and paint the area. Make sure your cut is no less than  $\frac{1}{4}$ " deep.

# INSTALLATION INSTRUCTIONS

25. Install the other lower control arm (same length as the first side) using supplied and original hardware. **Leave this side's upper control arm out for now.** Visually check the wheelbase positioning by comparing the axle and frame coil buckets and shock positioning. Adjust the wheelbase length as needed by threading in/out **both lower control arm adjusters equally.**

Next, set the vehicle at ride height. Reinstall this side's tire and use a jack stand to support the other end. To set the pinion angle:

- Support the pinion with a car jack
- Remove the upper control arm bolt at the frame bracket
- Use the jack to set the desired pinion angle (use a digital angle finder). We recommend 5.5°-6°
- Lengthen or shorten the upper control arm adjuster to achieve the desired angle and tighten
- Installing the other upper control arm on the other side to fit, without touching the jack. **The upper control arms do not need to be the same length and can vary slightly!**



Figure 30: Driver side lower and upper control arms installed

# INSTALLATION INSTRUCTIONS

26. Depending on various vehicle factors such as lift height, tire size, bump stops, and axle positioning, additional trimming near the rear body mount may be necessary to prevent interference at full suspension flex. It is essential to fully cycle the suspension and visually check for any potential contact points before finalizing the installation.

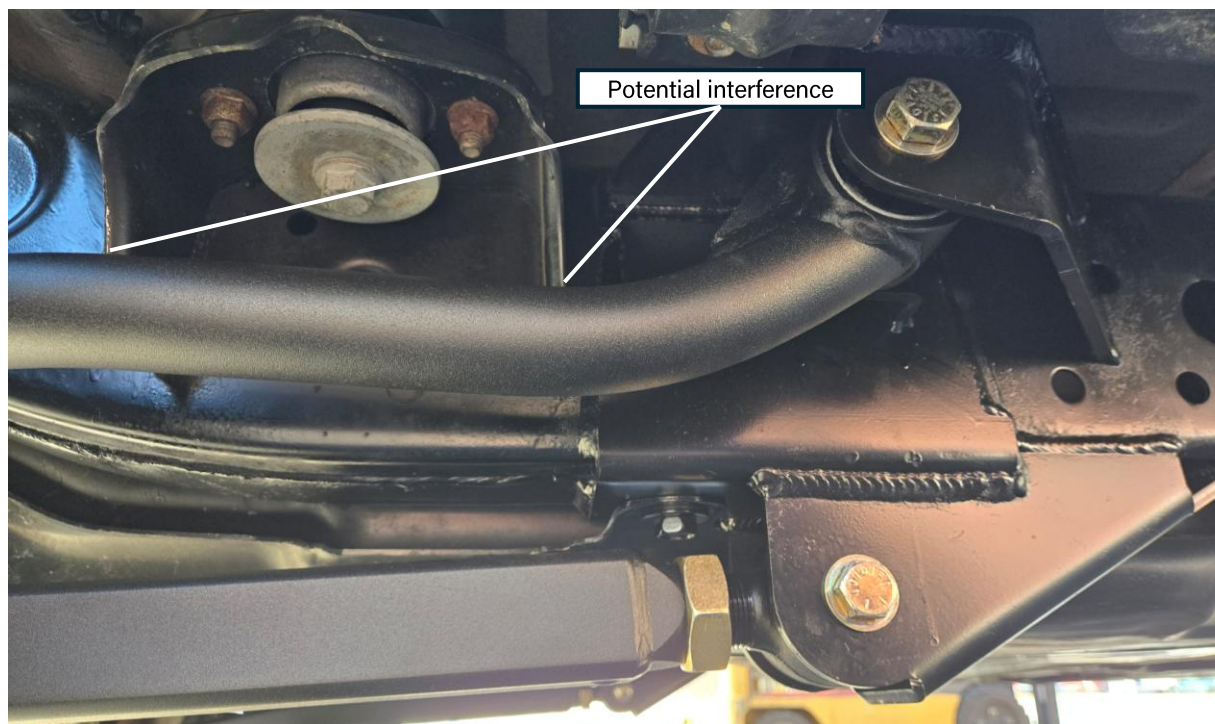

Figure 31: Potential interference point (rear-upper control arm and rear body mount)

# INSTALLATION INSTRUCTIONS

27. Reinstall the gas tank into the tank skid and prepare to fit it back into place. It is easier to balance the tank on two jack stands and slowly lift the tank back into its position. Once the tank sits 3-4 inches below its mounting location, reinstall the fuel lines at the front, top and rear of the tank. Use the original plastic clips to lock each connection. Reinstall any removed trim clips and reconnect the filler tube.

Make sure no connections are missing or loose. After all the lines are reconnected, bolt the tank back into place using an 18mm socket.



Figure 32: Gas tank ready to be installed back into mounting position

# INSTALLATION INSTRUCTIONS

28. Torque all hardware. Refer to the table below for helpful torque specifications. It is recommended to retorque all bolts after the first 500 miles of driving.

Table 2: COR REAR Long Arm Torque Specifications

Bolt Location	Wrench Size	Torque (ft-lbs)
Upper Control Arm Frame Bolt (9/16"-18 x 4")	13/16" and 7/8"	170
Upper Control Arm Axle Bolt (Factory Size)	21mm	125
Lower Control Arm Frame Bolt (9/16"-18 x 4")	13/16" and 7/8"	170
Lower Control Arm Axle Bolt (Factory Size)	21mm	125

# INSTALLATION INSTRUCTIONS

29. Tighten down the jam nuts on the upper and lower control arms. Use a 1-7/8" wrench for the lower control arm jam nuts, and a 1-1/2" wrench for the upper control arm jam nuts. Use a breaker bar to gain additional leverage. Tighten all jam nuts down as tight as humanly possible.

Please note that not all wrenches are created with the same tolerances. If your wrenches are too loose around the jam nut, Clayton Off Road offers tight, wrap-around wrenches for purchase. Please search for the wrenches using the SKU's below.



Figure 33: COR Wrench-ends for control arm jam nuts (COR-2500125, COR-2500100)

# INSTALLATION INSTRUCTIONS

30. Once the frame and brackets are painted and the control arms are torqued to specification, follow the post-installation checklist to complete the installation. As always, feel free to contact us with any questions you may have about the installation.



## POST-INSTALLATION CHECKLIST:

- Frame brackets are properly welded entirely to the frame
- The work area is fully painted
- Exhaust is completely reinstalled and tightened at all flanges/clamps
- Differential sensors are plugged back in
- O<sub>2</sub> sensors are plugged back in
- Coolant/brake lines are put back into place and are not damaged
- All hardware is torqued to specification (see Step 28)
- Control arm jam nuts are as tight as possible
- Lug nuts are torqued to the manufacturer's specification
- A licensed shop has professionally aligned the vehicle
- Retorque all hardware after 500 miles of driving

